

SPE06S60H-A

主要参数 MAIN CHARACTERISTICS

600V/6A 3 相全桥驱动	
V_{CES}	600V
I_c	6A
V_{ISO}	1500V

用途

- 风机
- 水泵
- 油烟机
- 风扇

APPLICATIONS

- Fan motor
- Water pump
- Lampblack machine
- Electric fan

产品特性

- 信号高电平有效，兼容 3.3V 和 5V 的 MCU.
- 内置自举二极管
- 内置欠压保护、过流保护。
- 使能关断功能
- 温度检测输出
- 绝缘耐压 1500V

FEATURES

- Signal high level valid, compatible with 3.3v and 5V MCU.
- Built-in bootstrap diode.
- Built-in undervoltage protection、Over current protection.
- Shut-Down Input
- thermistor detection output.
- Resistant to high voltage 1500V.

封装 Package

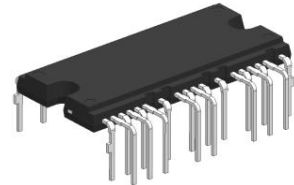

DIP26-FP

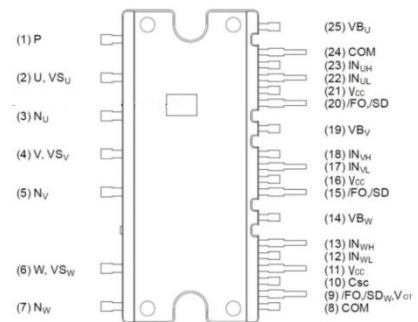

PIN1-PIN25

订货信息 ORDER MESSAGE

订货料号 Order number	产品信息 Product information			
	无卤-条管 Halogen-Free-Tube	无卤-编带 Halogen-Free-Reel	印记 Marking	封装 Package
2A01-1005	SPE06S60H-A	N/A	SPE06S60H-A	DIP26-FP

模块分布示意图 Module distribution diagram



图 1: 模块内部电路示意图

Fig 1: Internal circuit

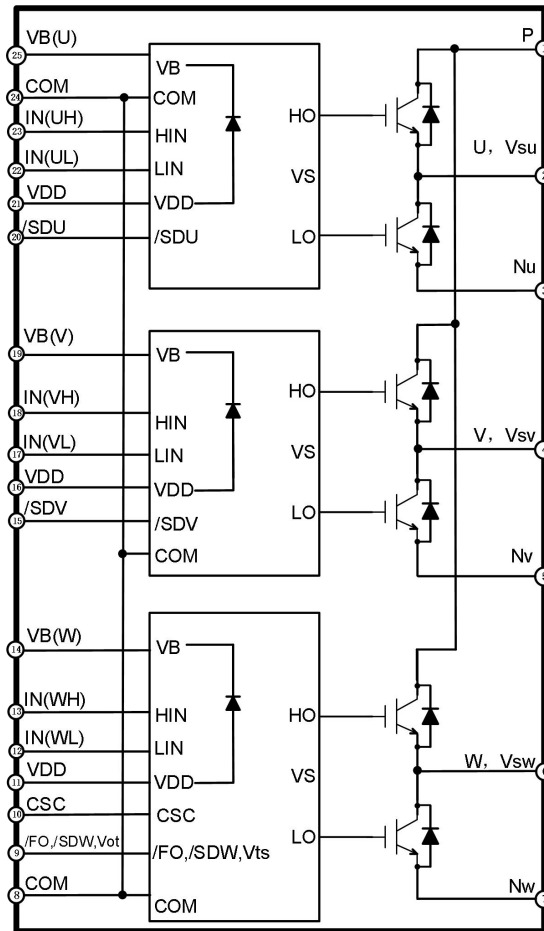

图 2: 模块引脚分布示意图

Fig 2: Distribution of pin

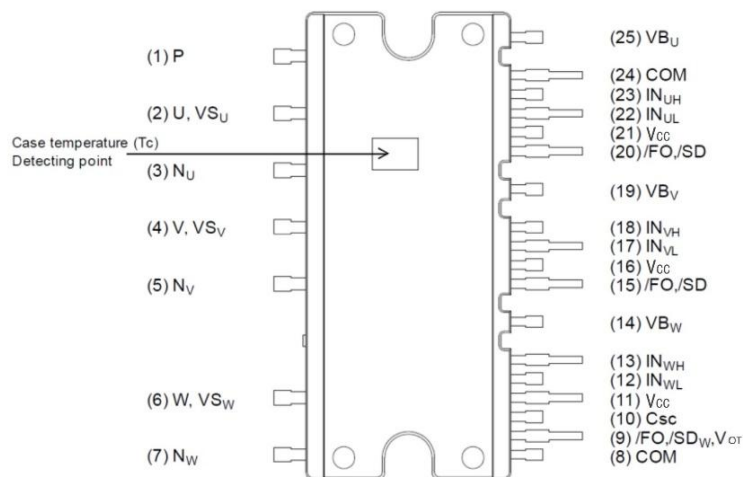

引脚编号 Number	引脚名称 Name	引脚描述 Description
1	P	逆变器直流输入端子 Dc input terminal of inverter
2	U, VS _U	U 相输出和 U 相高侧驱动偏置电压地 Output for U-Phase & Bias Voltage Ground for U-phase High-Side Driving
3	N _U	U 相下臂 IGBT 发射极端子 U phase lower arm IGBT emitter terminal
4	V, VS _V	V 相输出和 V 相高侧驱动偏置电压地 Output for V-Phase & Bias Voltage Ground for V-phase High-Side Driving
5	N _V	V 相下臂 IGBT 发射极端子 V phase lower arm IGBT emitter terminal
6	W, VS _W	W 相输出和 W 相高侧驱动偏置电压地 Output for W-Phase & Bias Voltage Ground for W-phase High-Side Driving
7	N _W	W 相下臂 IGBT 发射极端子 W phase lower arm IGBT emitter terminal
8	COM	公共电源接地 GND Common Supply Ground
9	/FO, /SD _W , VOT	故障输出, W 相输入关闭, 温度输出 Fault Output, Shut-Down Input for W Phase, Temperature Output
10	CSC	过流和短路保护关闭输入端子 Shut Down Input for Over Current and Short Circuit Protection
11	V _{CC}	控制电源端子 Control power terminal
12	IN _{WL}	W 相下臂控制信号输入端子 W phase lower arm control signal input terminal
13	IN _{WH}	W 相上臂控制信号输入端子 W phase upper arm control signal input terminal
14	VB _W	W 相上臂驱动电源端子 W phase upper arm drive power terminal
15	/FO/SD _V	V 相输入关闭 Shut-Down Input for V Phase
16	V _{CC}	控制电源端子 Control power terminal
17	IN _{VL}	V 相下臂控制信号输入端子 V phase lower arm control signal input terminal
18	IN _{VH}	V 相上臂控制信号输入端子 V phase upper arm control signal input terminal
19	VB _V	V 相上臂驱动电源端子 V phase upper arm drive power terminal
20	/FO/SD _U	U 相输入关闭 Shut-Down Input for U Phase
21	V _{CC}	控制电源端子 Control power terminal
22	IN _{UL}	U 相下臂控制信号输入端子 U-phase lower arm control signal input terminal
23	IN _{UH}	U 相上臂控制信号输入端子 U-phase upper arm control signal input terminal
24	COM	公共电源接地 GND Common Supply Ground
25	VB _U	U 相上臂驱动电源端子 U-phase upper arm drive power terminal

图 3: 模块引脚功能定义表

Fig 3: Pin function

最大额定值 (T_J= 25°C, 除非特殊说明)Absolute Maximum Ratings (T_J= 25°C, Unless otherwise Specified)

逆变部分 Inverter Part

记号 Symbol	参数 Parameter	条件 Condition	额定值 Ratings	单位 Units
V _{PN}	电源电压 Power supply voltage	应用于 P- NU, NV, NW 之间 Applied between P- NU, NV, NW	450	V
V _{PN(Surge)}	电源电压 (含浪涌) Power supply voltage (including surge)	应用于 P- NU, NV, NW 之间 Applied between P- NU, NV, NW	500	V
V _{CES}	单个 IGBT 的集电极-发射极电压 Collector-Emitter Voltage of Each IGBT		600	V
I _C	集电极连续电流 Each IGBT Current, Continuous	T _C = 25°C,	6.0	A
I _{CM}	集电极电流 (峰值) Each IGBT Pulse Current, Peak	T _C =25°C, 脉冲宽度小于 1ms T _C =25°C, less than 1ms	12.0	A
P _C	集电极功耗 Maximum Power Dissipation	TC = 25° C, 单晶片 TC = 25° C, Each IGBT	15	W
T _J	结温 Junction Temperature	(见备注 1) Note1	-40~150	° C

控制部分 Control Part

记号 Symbol	参数 Parameter	条件 Condition	额定值 Ratings	单位 Units
V _{CC}	控制电源电压 Control Supply Voltage	V _{CC} -COM 之间 Applied between V _{CC} and COM	20	V
V _{BS}	高侧控制电压 High-side Bias Voltage	VB-VS 之间 Applied between VB and VS	20	V
V _{IN}	输入信号电压 Input Signal Voltage	V _{IN} -COM 之间 Applied between V _{IN} and COM	-0.3~V _{CC} +0.3	V
V _{FO}	故障输出电压 Function Supply Voltage	V _{FO} -COM 之间 Applied between V _{FO} and COM	-0.3~V _{CC} +0.3	V
V _{SC}	过流触发电压 Current Sensing Input Voltage	V _{SC} -COM 之间 Applied between V _{SC} and COM	-0.3~V _{CC} +0.3	V

整个系统 Total System

记号 Symbol	参数 Parameter	条件 Condition	额定值 Ratings	单位 Units
V _{PN(PROT)}	自我保护电源电压限制 Self-protecting power supply voltage limit	V _{CC} =V _{BS} =13.5V~16.5V, T _J =125°C, 非重复性, <2us	400	V
T _J	工作结温范围 Operating Junction Temperature	见备注1	-20~125	°C
T _C	模块壳体工作温度 Module shell temperature	-	-20~100	°C
T _{STG}	贮存温度 Storage Temperature	-	-40~125	°C
V _{ISO}	绝缘耐压 Isolation Voltage	60Hz, 正弦, AC 1 分钟, 连接管脚到散热器 60Hz, Sinusoidal, AC 1 min, between pins and heat-sink plate	1500	Vrms



备注 1: IPM 功率芯片最大额定结温为 150°C(@表面温度 $T_C \leq 100^\circ\text{C}$)。然而,为了确保 IPM 运行安全, 结温应限定于 $T_{j(av)} \leq 125^\circ\text{C}$ (@表面温度 $T_c \leq 100^\circ\text{C}$)。

Note 1: The maximum rated junction temperature of the IPM power chip is 150°C (@surface temperature $T_C \leq 100^\circ\text{C}$). However, to ensure safe operation of the IPM, the junction temperature should be limited to $T_{j(av)} \leq 125^\circ\text{C}$ (@surface temperature $T_C \leq 100^\circ\text{C}$)

热阻 Thermal Resistance

记号 Symbol	参数 Parameter	条件 Condition	额定值 Ratings	单位 Units
Rth(j-c)Q	结到外壳的热阻 Junction to Case Thermal resistance	逆变器工作条件下的单个IGBT Each IGBT	7.6	$^\circ\text{C}/\text{W}$
Rth(j-c)F	结到外壳的热阻 Junction to Case Thermal resistance	逆变器工作条件下的单个FRD Each FRD	7.8	$^\circ\text{C}/\text{W}$

备注 2: 关于壳体温度 (TC) 的测量点, 参见图 2。

Note 2: For the measurement point of shell temperature (TC), see Figure 2.

电气特性 (T_j=25°C, 除非特殊说明)

Electrical Characteristics (T_J=25°C, Unless Otherwise Specified)

逆变部分 Inverter Part

记号 Symbol	参数 Parameter	条件 Condition	最小值 Min.	典型值 Typ.	最大值 Max.	单位 Unit
V _{CESAT}	饱和压降 Collector-Emitter saturation Voltage	V _D =V _{DB} =15V, V _{IN} =5V, I _C =5A, T _J =25° C	-	1.7	2.2	V
V _F	FRD 正向电压 FRD Forward voltage	V _{IN} =0V, I _C =-5A	-	2	2.3	V
I _{CES}	集电极-发射极间漏电流 Collector emitter leakage current	V _{CE} =V _{CES}	-	-	10	uA
t _{ON}	开关时间 (备注3) Switching Times(Note 3)	V _{PN} =400 V, V _{CC} = V _{BS} = 15 V, I _C =6 A V _{IN} = 0 V ↔5 V, 电感负载 / Inductive Load	-	500	-	nS
t _{C(ON)}			-	190	-	nS
t _{OFF}			-	600	-	nS
t _{C(OFF)}			-	60	-	nS
t _{rr}			-	130	-	nS
E _{ON}			-	230	-	uJ
E _{OFF}			-	85	-	uJ

备注 3: t_{ON} 和 t_{OFF} 包括驱动 IC 内部传输延迟时间。t_{C(ON)} 和 t_{C(OFF)} 是 IGBT 自身被内部给定门极驱动条件下的开关时间。详见图 4。

Note 3: t_{ON} and t_{OFF} include the internal transmission delay time of the driver IC. t_{C(ON)} and t_{C(OFF)} are the switching times of the IGBT itself driven by the internally given gate. See Figure 4 for details.



图 4：开关时间定义

Fig 4: Switching Time Definition

控制部分 Control Part

记号 Symbol	参数 Parameter	条件 Condition		最小值 Min.	典型值 Typ.	最大值 Max.	单位 Unit
I _{QCC}	VCC 静态电流 Quiescent VCC Supply Current	VCC=15V VIN=5V	VCC-COM 之间 Applied between VCC and COM	-	-	1	mA
I _{QB}	VBS 静态电流 Quiescent VBS Supply Current	VDB=15V VIN=0V	VB(U)-U, VB(V)-V, VB(W)-W 之间 Applied between VB(U)-U, VB(V)-V, VB(W)-W	-	-	500	uA
UVCCD	低侧欠压保护 Low-Side Under-Voltage Protection	检测电平 VCC Under-Voltage Protection Detection Level		7.2	8.2	9.2	V
UVCCR		复位电平 VCC Under-Voltage Protection Reset Level		8.2	9.2	10.2	V
UVBSD	高侧欠压保护 High-Side Under-Voltage Protection	检测电平 VBS Under-Voltage Protection Detection Level		7.0	8.0	9.0	V
UVBSR		复位电平 VBS Under-Voltage Protection Reset Level		7.5	8.5	9.5	V
t _{FOD}	故障输出脉冲宽度 Fault-Out Pulse Width	-		20	-	-	us
VOT	温度输出, 备注 4 Temperature output, remark 4	温度 25°C, 通过 10KΩ 电阻下拉至 5V Tc=25°C, 10K to 5V Pull-up		-	4.26	-	V
		温度 25°C, 通过 10KΩ 电阻下拉至 5V Tc=75°C, 10K to 5V Pull-up		-	2.8	-	
V _{IH}	输入开启阈值电压 ON Threshold Voltage	逻辑高电平, 加在 VIN 与 COM 之间 Logic HIGH Level, Applied between VIN and COM		-	2.6	3.0	V
V _{IL}	输入关闭阈值电压 OFF Threshold Voltage	逻辑低电平, 加在 VIN 与 COM 之间 Logic Low Level, Applied between VIN and COM		0.8	1.6	-	V
IFO_T	HVIC 温度检测输出电流 HVIC Temperature Sensing Current Output	VDD=VBS=15V,T=25°C (备注 5)		-	82.5	-	uA
		VDD=VBS=15V,T=75°C (Note 5)		-	207.5	-	
VFO_T	HVIC 温度检测输出电压	VDD=VBS=15V,T=25°C,10K to 5V Pull-up		-	4.18	-	V

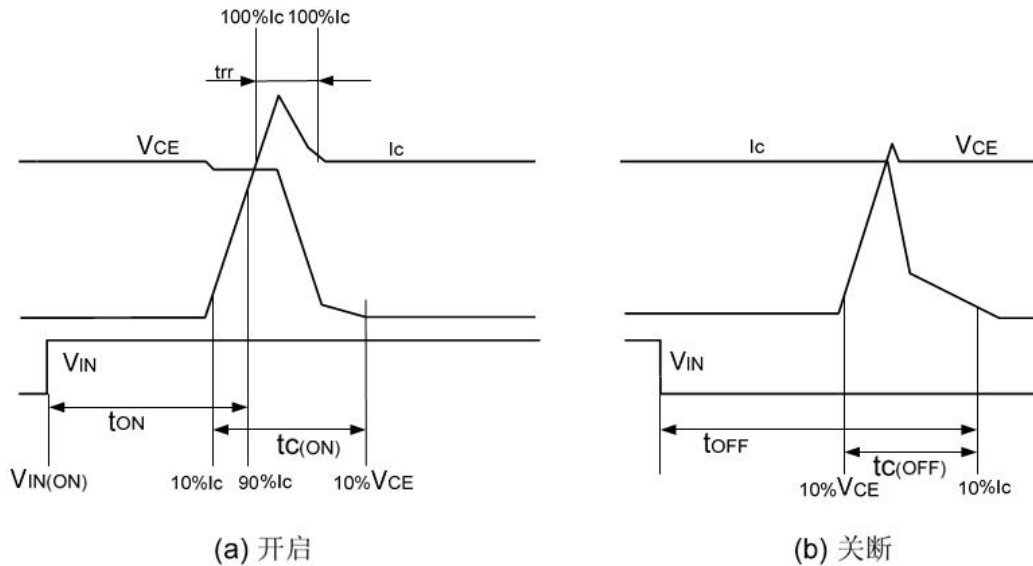

	HVIC Temperature Sensing Voltage Output	VDD=VBS=15V,T=75°C, 10K to 5V Pull-up	-	2.93	-	
V _{FSDR}	使能关断复位电平 Shut-down Reset level	SDx-COM	1.7	2.2	2.6	V
V _{FSDD}	使能关断阈值电压 Shut-down Detection level	SDx-COM	0.8	1.5	2.0	V
I _{IN}	输入偏执电流 Input bias current	V _{IN} =5V	0.7	0.9	1.1	mA
V _{SC(ref)}	短路跳闸阈值 Short-Circuit Trip Level	-	0.38	0.44	0.50	V

备注 4: 如果管脚/FO, /SDW, /VTS 和其它 SDX 连接在一起时, 短路(过流)保护对 6 个 MOSFET 都有效。

Note 4: If pins /FO,/SDW,/VTS, and other SDX are connected together, short-circuit (overcurrent) protection is effective for all six MOSFETs.

自举二极管部分 Bootstrap Diode Part

记号 Symbol	参数 Parameter	条件 Condition	最小值 Min.	典型值 Typ.	最大值 Max.	单位 Unit
RBS	自举二极管阻值 Bootstrap Diode Resistance	集成在 HVIC 内 (备注 5) Integrated Within HVIC (Note 5)	-	100	-	Ω

备注 5: IPM 内部自举二极管集成在 HVIC 上, 采用复合器件代替外置的快恢复二极管, 恢复特性优于 FRD。

Note 5: The IPM internal bootstrap diode is integrated on the HVIC, using composite devices instead of external fast recovery diodes for better recovery characteristics.

推荐工作条件 Recommended Operating Conditions

记号 Symbol	参数 Parameter	条件 Condition	最小值 Min.	典型值 Typ.	最大值 Max.	单位 Unit
V _{PN}	电源电压 Supply Voltage	施加在 P 和 N 之间 Between P and N	-	300	400	V
V _{CC}	控制电源电压 Control Supply Voltage	施加在 V _{CC} 和 COM 之间 Between V _{CC} and COM	13.5	15.0	16.5	V
V _{BS}	高端偏压 High-Side Bias Voltage	施加在 V _B 和 V _S 之间 Between V _B and V _S	13.5	15.0	18.5	V
d _{VCC/dt} , d _{VBS/dt}	控制电源波动 Control power fluctuation		-1	-	1	V/us
V _{IN(ON)}	输入的开启电压 ON Threshold Voltage	施加在 V _{IN} 和 COM 之间 Applied between V _{IN} -COM	3.0	-	V _{CC}	V
V _{IN(OFF)}	输入的关闭电压 OFF Threshold Voltage	施加在 V _{IN} 和 COM 之间 Applied between V _{IN} -COM	0	-	0.8	V
t _{dead}	防止桥臂直通的死区时间 Blanking Time for Preventing Arm-Short	V _{CC} = V _{BS} = 13.5 ~ 16.5 V, T _J ≤ 150°C	1.0	-	-	us
F _{PWM}	PWM 开关频率 PWM Switching Frequency	T _J ≤ 150°C	-	-	20	KHz



PWM	最小输入信号脉冲宽度	$P_{WIN(ON)}$	0.7	-	-	us
	Minimum input signal pulse width	$P_{WIN(OFF)}$	0.7	-	-	us



图 5: HVIC 温度检测输出温度—电流曲线

Fig 5: Curves of HVIC Temperature-Current Output

保护功能时序图 Time Charts of Protective Function

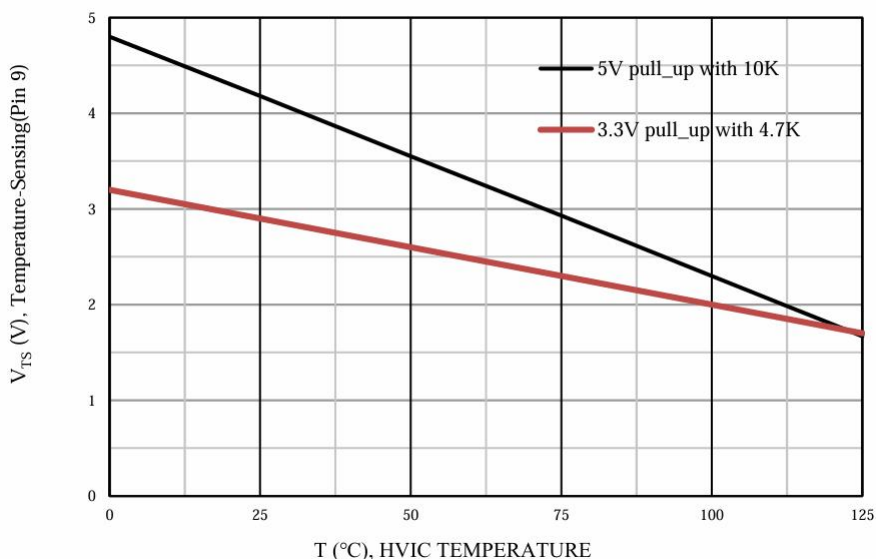

图 6: 欠压保护时序图(低侧)

Fig 6: Undervoltage protection sequence diagram (low side)

a1 :电源电压上升: 电压上升至 UV_{CCB} , 当下一个输入信号到来时电路开始工作;

- a1 : Control supply voltage rises: after the voltage rises UV_{CCR} , the circuits start to operate when next input is applied.
- a2: 正常运行: MOSFET 开启并加载电流。
- a2: Normal operation: MOSFET turns on and loads current.
- a3: 欠压检测点(UV_{CCD})。
- a3: Undervoltage detection point (UV_{CCD}).
- a4: 不管输入是什么信号, MOSFET 都是关闭状态。
- a4: No matter what signal is input, the MOSFET is off.
- a5: 故障输出开启。
- a5: Fault output is on.
- a6: 欠压恢复(UV_{CCR})。
- a6: Undervoltage recovery (UV_{CCR}).
- a7: 正常运行: MOSFET 导通并加载负载电流。
- a7: Normal operation: MOSFET is turned on and load current is loaded.

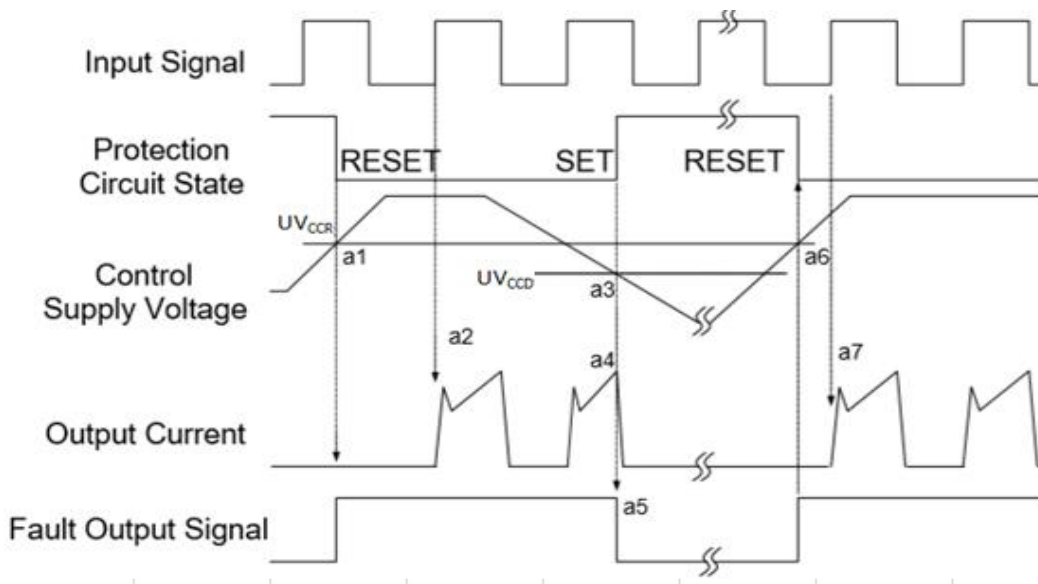

图 7: 欠压保护时序图(高侧)

Fig 7: Undervoltage protection sequence diagram (High side)

- b1 : 电源电压上升: 当该电压上升到欠压恢复点, 在下一个欠压信号被执行前该线路将启动运行。
- b1: Power supply voltage rise: When the voltage rises to the undervoltage recovery point, the line will start running before the next undervoltage signal is executed.
- b2 : 正常运行: MOSFET 导通并加载负载电流。
- b2: Normal operation: MOSFET is turned on and load current is applied.
- b3 : 欠压检测 (UV_{BSD})。
- b3: Undervoltage detection (UV_{BSD}).
- b4 : 不管输入是什么信号, MOSFET 都是关闭状态。
- b4: No matter what signal is input, MOSFET is off.
- b5 : 欠压恢复(UV_{BSR})。
- b5: Undervoltage recovery (UV_{BSR})。 .
- b6 : 正常运行: MOSFET 导通并加载负载电流。
- b6: Normal operation: MOSFET is turned on and load current is applied.

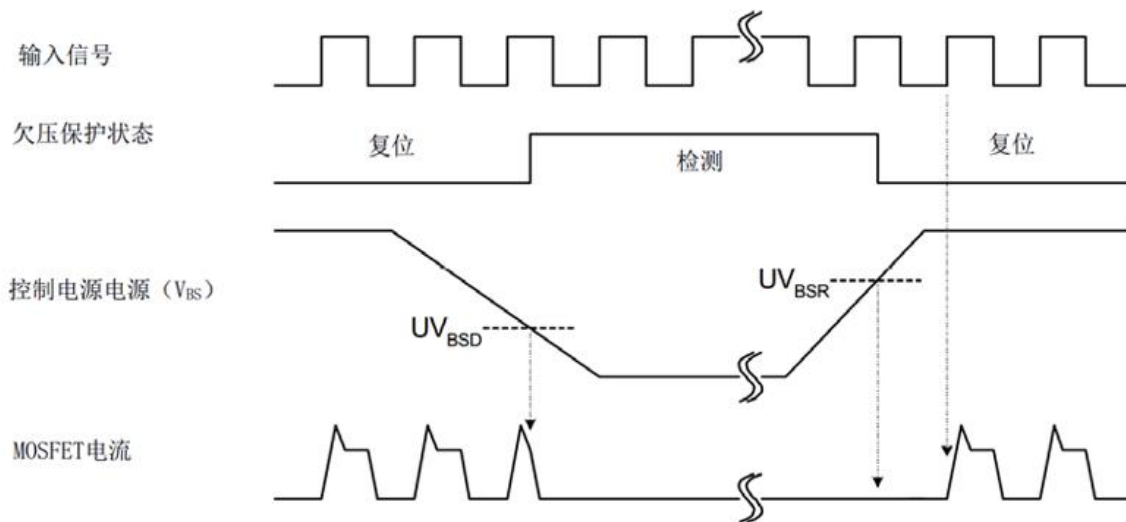

图 8：短路保护时序图

Fig 8: Short circuit protection sequence diagram

HIN :高侧输入信号;

HIN : High-side Input Signal

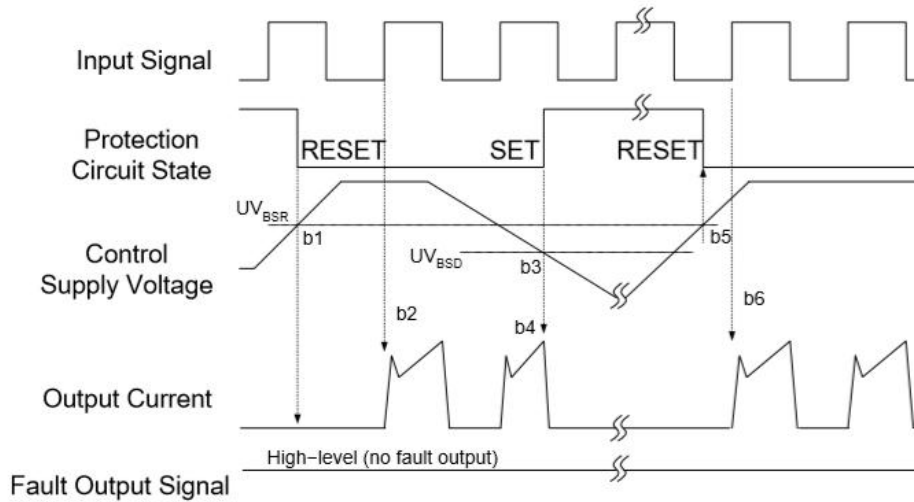
LIN : 低侧输入信号;

LIN : Low-side Input Signal

HO : 高侧输出信号;

HO : High-Side Output Signal

LO : 低侧输出信号;

LO : Low-Side Output Signal

CSC :过流侦测信号;

CSC : Over Current Detection Input

/FO:故障输出信号

/FO : Fault Out Function



图 9. 外部关断功能时序

Figure 9. Shutdown Input Function by External Command

HIN :高侧输入信号;
HIN : High-side Input Signal
LIN : 低侧输入信号;
LIN : Low-side Input Signal
HO : 高侧输出信号;
HO : High-Side Output Signal
LO : 低侧输出信号;
LO : Low-Side Output Signal
CSC :过流侦测信号;
CSC : Over Current Detection Input
/SDx:外部关断输入信号
/SDx : Shutdown Input Function

输入输出接口电路 Input/output interface circuit

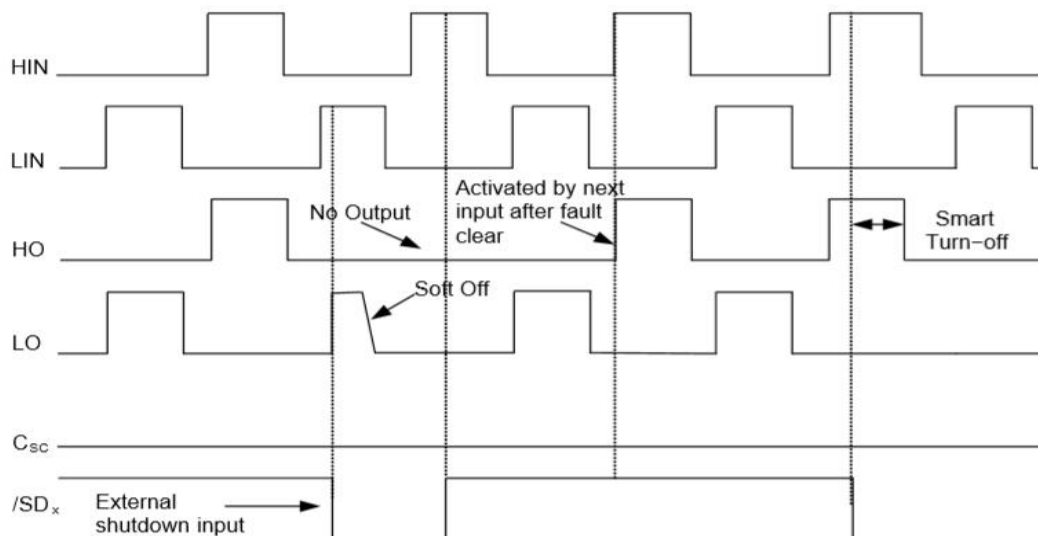

图 10. 推荐的 MCU I/O 接口电路

Figure 10: Recommended MCU input and output interface circuit

备注 6: 由于 PWM 的控制方式和实际应用电路的阻抗及线路板的阻抗, RC 去耦可能会有变化。

Note 6: Due to the PWM control method and the impedance of the actual application circuit and the impedance of the circuit board, RC decoupling may change.

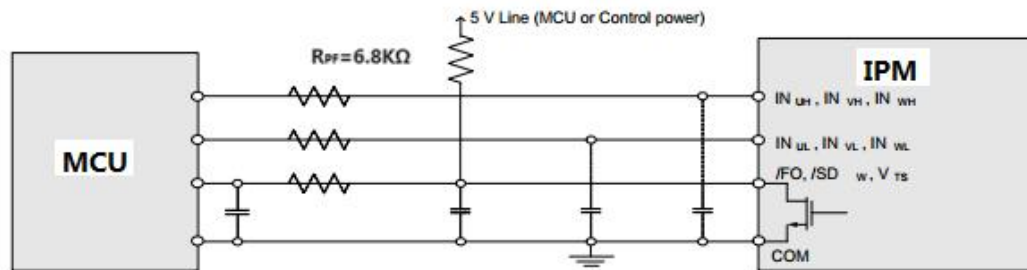
应用电路 Application Circuit



图 11: 典型应用电路图

Fig 11: Example of Application Circuit

备注 7: .关于引脚的位置请参阅图 1.

Note 7: Refer to figure 1 for pin location.

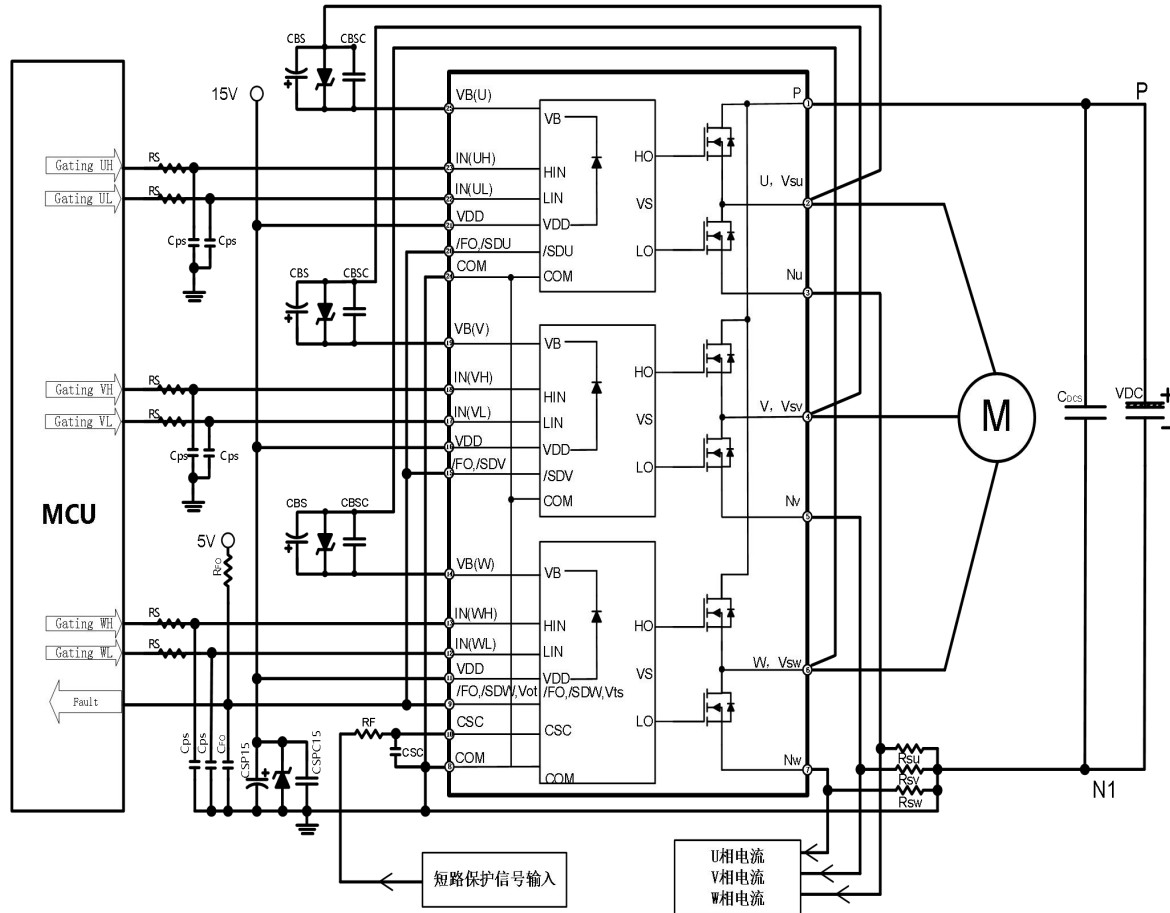
备注 8:为避免故障, 各输入接线应尽可能短。

Note 8:To avoid malfunction, the wiring of each input should be as short as possible

备注 9:为防止浪涌损坏, PN 之间建议增加一个高频非感性平复电容 (0.1 μ F~0.22 μ F), 电容的连线要尽量短。

Note 9:To prevent surge destruction, it is recommended to add a high-frequency non inductive smoothing capacitor (0.1 μ F~0.22 μ F) between PN, and the wiring of the capacitor should be as short as possible.

备注 10:输入信号高电平有效, 在 HVIC 每个通道的输入端都有一个下拉电阻连接到地; 建议在输入端增加 RC 滤波电路来防止输入信号振荡。

Note 10: The high level of the input signal is effective, and a pull-down resistor is connected to the ground at the input terminals of each channel of HVIC; It is suggested to add RC filter circuit at the input terminals to prevent input signal oscillation.

备注 11:所有电容的位置尽可能的靠近 IPM。

Note 11: Position all capacitors as close to IPM as possible.

备注 12:控制地线和电源地线要连接在一个点, 走线尽量短;



Note 12: The control ground wire and power ground wire shall be connected at one point, and the wiring shall be as short as possible;

备注 13: 在短路保护电路, 请选择时间常数在 1.5~2us 范围内的 RF 和 CSC, 同时 RF 和 CSC 周边的接线都应尽量短, RF 接线应靠近分流电阻;

Note 13: In the short-circuit current protection circuit, please select the RF CSC time constant in the range 1.5~2us, At the same time, the wiring around RF and CSC shall be as short as possible, and RF wiring shall be close to shunt resistance;

备注 14: /FO, /SD 的连线尽可能短。

Note 14: /FO and /SD must be connected as short as possible.



外形封装图 Detailed Package Outline Drawings

DIP26-FP

单位：mm



图 12： 封装外形图

Fig 12: Package Outline Drawings

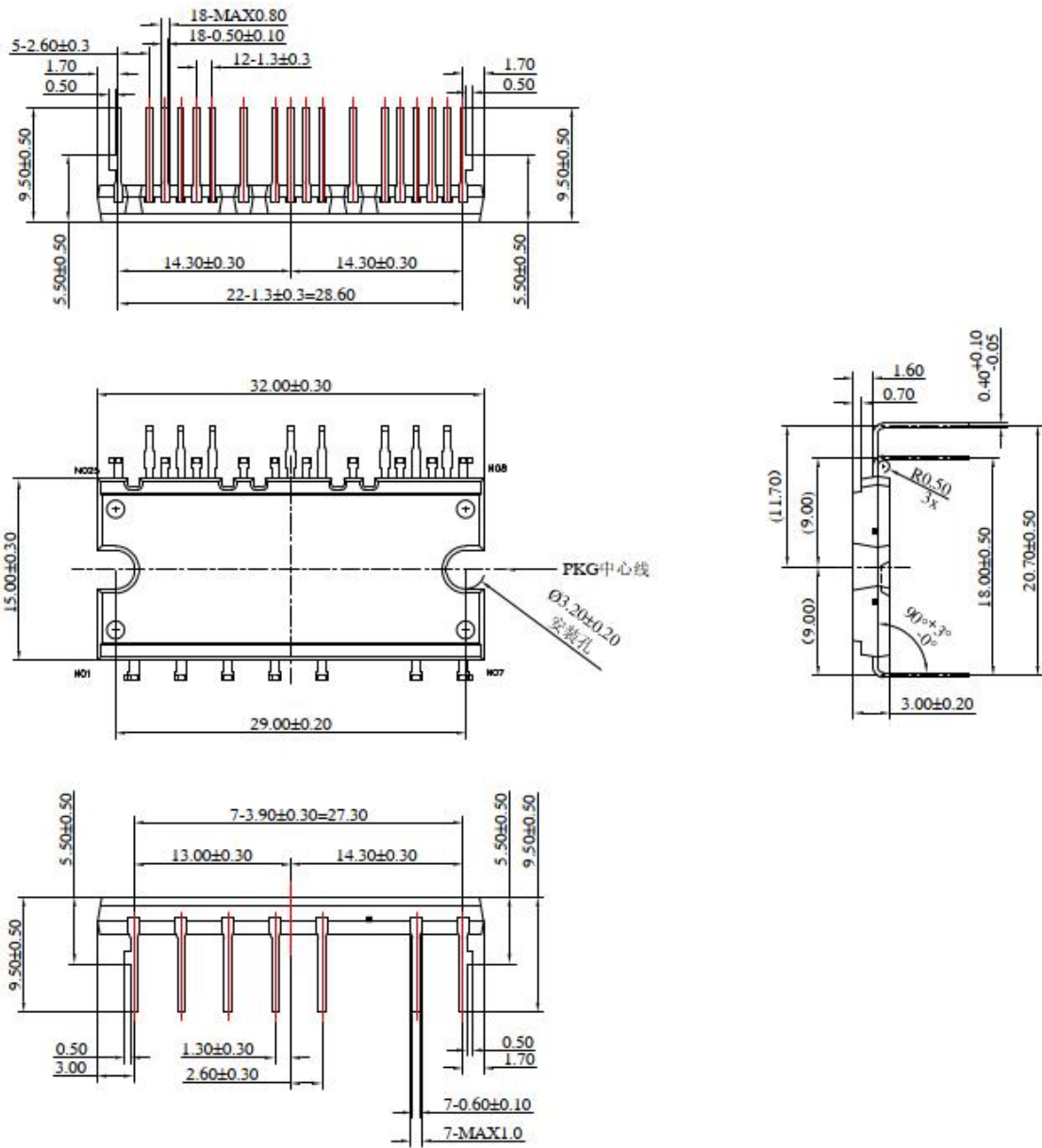

注意事项

1. 吉林华微电子股份有限公司的产品销售分为直销和销售代理，无论哪种方式，订货时请与公司核实。
2. 购买时请认清公司商标，如有疑问请与公司本部联系。
3. 在电路设计时请不要超过器件的绝对最大额定值，否则会影响整机的可靠性。
4. 本说明书如有版本变更不另外告知。

NOTE

1. Jilin Sino-microelectronics co., Ltd sales its product either through direct sales or sales agent , thus, for customers, when ordering , please check with our company.
2. We strongly recommend customers check carefully on the trademark when buying our product, if there is any question, please don't be hesitate to contact us.
3. Please do not exceed the absolute maximum ratings of the device when circuit designing.
4. Jilin Sino-microelectronics co., Ltd reserves the right to make changes in this. specification sheet and is subject to change without prior notice.

联系方式

吉林华微电子股份有限公司

公司地址：吉林省吉林市深圳街 99 号

邮编：132013

总机：86-432-64678411

传真：86-432-64665812

网址：www.hwdz.com.cn

CONTACT

JILIN SINO-MICROELECTRONICS CO., LTD.

ADD: No.99 Shenzhen Street, Jilin City, Jilin Province, China.

Post Code: 132013

Tel: 86-432-64678411

Fax: 86-432-64665812

Web Site: www.hwdz.com.cn