



# MG065R180B

## 主要参数 MAIN CHARACTERISTICS

$I_D$	19A
$V_{CE}$	650V
$R_{dson-typ}$ (@ $V_{gs}=15V$ )	187m $\Omega$
$Q_g-typ$	15.3nC

### 用途

- 光伏逆变器
- 开关模式电源
- 高压 DC/DC 转换器
- 电池充电器
- 电动驱动
- 脉冲电源应用

### APPLICATIONS

- Solar Inverters
- Switch Mode Power Supplies
- High Voltage DC/DC Converters
- Battery Chargers
- Motor Drives
- Pulsed Power applications

### 产品特性

- 高阻断电压
- 低导通电阻
- 低电容高速开关
- 易于驱动
- RoHS 产品

### FEATURES

- High Blocking Voltage
- Low On-Resistance
- High Speed Switching with Low Capacitances
- Easy to Parallel and Simple to Drive
- RoHS product

## 封装 Package

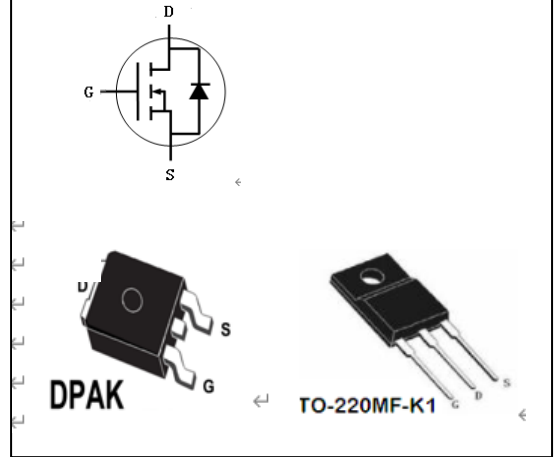

## 订货信息 ORDER MESSAGE

订货型号 Order codes				印记 Marking	封装 Package
有卤-条管 Halogen-Tube	无卤-条管 Halogen-Free-Tube	有卤-编带 Halogen-Reel	无卤-编带 Halogen-Free-Reel		
N/A	MG065R180B-R-BR	N/A	MG065R180B-R-AR	MG065R180B	DPAK
N/A	MG065R180B-F1-BR	N/A	N/A	MG065R180B	TO-220MF-K1

绝对最大额定值 ABSOLUTE RATINGS ( $T_c=25^{\circ}\text{C}$ )

项 目 Parameter	符 号 Symbol	数 值 Value	单 位 Unit	测试条件 Tests conditions
最高漏极-源极直流电压 Drain-Source Voltage	$V_{DSmax}$	650	V	$V_{GS}=0V, I_D=100\mu A$
最高栅源电压 Gate-Source Voltage	$V_{GSmax}$	-10/+22	V	Absolute maximum values
工作栅源电压 Gate-Source Voltage	$V_{GSop}$	0/+15	V	Recommended operational values
连续漏极电流 Drain Current -continuous	$I_D$	19	A	$T_C=25^{\circ}\text{C}$
		13.5	A	$T_C=100^{\circ}\text{C}$
最大脉冲漏极电流 Drain Current - pulse	$I_{DM}$	33	A	Pulse width $t_p$ limited by $T_{jmax}$
耗散功率 Power Dissipation	$P_D$	76	W	$T_C=25^{\circ}\text{C}$
单脉冲雪崩能量 Single Pulsed Avalanche Energy	$E_{AS}$	33.4	mJ	$L=0.5\text{mH}, I_{AS}=8.1\text{A}, V_{DD}=50\text{V}, V_{GS}=15\text{V}$
最高结温及存储温度 Operating and Storage Temperature Range	$T_J, T_{STG}$	-55~+175	$^{\circ}\text{C}$	
引线最高焊接温度 Maximum Lead Temperature for Soldering Purposes	$T_L$	260	$^{\circ}\text{C}$	



## 电特性 ELECTRICAL CHARACTERISTICS

项 目 Parameter	符 号 Symbol	测试条件 Tests conditions	最小 Min	典型 Typ	最大 Max	单位 Units
漏-源击穿电压 Drain-Source Voltage	$BV_{DSS}$	$I_D=100\mu A, V_{GS}=0V$	650	-	-	V
阈值电压 Gate Threshold Voltage	$V_{GS(th)}$	$V_{DS} = V_{GS}, I_D=10mA, T_C=25^\circ C$	-	3.9	-	V
		$V_{DS} = V_{GS}, I_D=10mA, T_C=175^\circ C$	-	2.8	-	V
零栅压下漏极漏电流 Zero Gate Voltage Drain Current	$I_{DSS}$	$V_{DS}=650V, V_{GS}=0V, T_C=25^\circ C$	-	0.1	20	$\mu A$
		$V_{DS}=650V, V_{GS}=0V, T_C=175^\circ C$	-	1	-	
栅极体漏电流 Gate-body leakage current	$I_{GSS}$	$V_{DS}=0V, V_{GS} =22V, T_C=25^\circ C$	-	1	250	nA
		$V_{DS}=0V, V_{GS} =-10V, T_C=25^\circ C$	-			
导通电阻 Drain-Source On-Resistance	$R_{DS(ON)}$	$V_{GS} =15V, I_D=7A, T_C=25^\circ C$	-	187	215	m $\Omega$
		$V_{GS} =15V, I_D=7A, T_C=175^\circ C$	-	175	-	m $\Omega$
跨导 Transconductance	$g_{fs}$	$V_{DS} = 20V, I_D=4A, T_J = 25^\circ C$	-	5	-	S
输入电容 Input capacitance	$C_{iss}$	$V_{DS}=650V,$ $V_{GS} =0V,$ $f=1MHz$	-	431	-	pF
输出电容 Output capacitance	$C_{oss}$		-	30	-	pF
反向传输电容 Reverse transfer capacitance	$C_{rss}$		-	3	-	pF
导通开关能量 Turn-On Switching Energy	$E_{ON}$	$V_{DD}=400V, V_{GS}=0/15V, I_D=7A,$ $R_{G(on)} = 2.2\Omega, L= 600\mu H$	-	67.8	-	$\mu J$
关断开关能量 Turn-Off Switching Energy	$E_{OFF}$		-	15	-	
延迟时间 Turn-On delay time	$t_{d(on)}$	$V_{DD}=400V, V_{GS}=0/15V, I_D= 7A,$ $R_{G(ext)} = 2.2\Omega, L= 600\mu H$	-	29.2	-	ns
上升时间 Turn-On rise time	$t_r$		-	11.7	-	ns
延迟时间 Turn-Off delay time	$t_{d(off)}$		-	46.1	-	ns
下降时间 Turn-Off Fall time	$t_f$		-	16.5	-	ns
栅电阻 Intrinsic gate resistance	$R_G$	$f = 1 MHz, V_{AC}=25mV$	-	36	-	$\Omega$
栅-源电荷 Gate-Source charge	$Q_{gs}$	$V_{DD}=400V, V_{GS}=0/15V, I_D =7A$	-	5.5	-	nC
栅-漏电荷 Gate-Drain charge	$Q_{gd}$		-	2.6	-	
栅极电荷总量 Total Gate Charge	$Q_g$		-	15.3	-	





## 漏-源二极管特性 Drain-Source Diode Characteristics

项 目 Parameter	符 号 Symbol	测试条件 Tests conditions	典型 Typ	最大 Max	单位 Units
正向压降 Drain-Source Diode Forward Voltage	$V_{SD}$	$V_{GS} = 0V, I_{SD} = 3.5A, T_J = 25\text{ }^{\circ}C$	3.3	-	V
		$V_{GS} = 0V, I_{SD} = 3.5A, T_J = 175\text{ }^{\circ}C$	2.8	-	V
正向最大连续电流 Maximum Continuous Drain -Source Diode Forward Current	$I_S$	$T_C = 25\text{ }^{\circ}C$	-	13.5	A
		$T_C = 100\text{ }^{\circ}C$	-	7.7	
反向恢复时间 Reverse recovery time	$t_{rr}$	$V_{GS} = 0V, I_{SD} = 7A, \text{dif/dt} = 2kA/\mu s,$ $V_{DS} = 400V \quad T_J = 25\text{ }^{\circ}C$	26	-	ns
反向恢复电荷 Reverse recovery charge	$Q_{rr}$		68	-	nC
峰值反向恢复电流 Peak Reverse Recovery Current	$I_{rrm}$		6.9	-	A
反向恢复能量 Reverse Recovery Energy	$E_{rr}$		5.0	-	$\mu J$

## 热特性 THERMAL CHARACTERISTIC

项 目 Parameter	符 号 Symbol	典型 Typ	单位 Unit
结到管壳的热阻 Thermal Resistance, Junction to Case	$R_{th(j-c)}$	1.98	$^{\circ}C/W$
结到环境的热阻 Thermal Resistance, Junction to Ambient	$R_{th(j-A)}$	40	$^{\circ}C/W$





## 外形尺寸 PACKAGE MECHANICAL DATA

## TO-220MF-K1

单位 Unit: mm

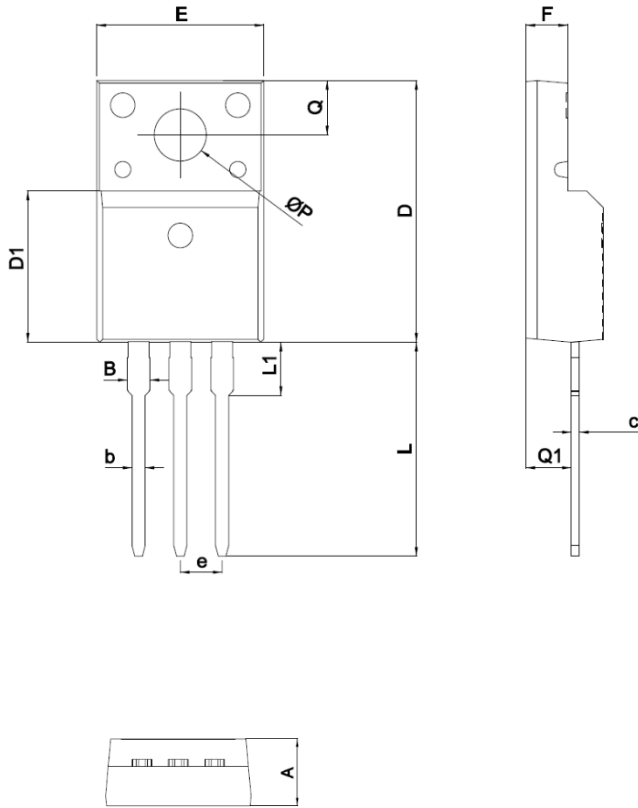

SYMBOL	mm	
	MIN	MAX
A	4.5	4.9
B	1.22	1.47
b	0.7	0.9
c	0.45	0.60
D	15.6	16.1
D1	9.0	9.3
e	2.54TYPE	
E	9.9	10.4
F	2.3	2.8
L	12.6	13.3
L1	3.1	3.4
Q	3.2	3.4
Q1	2.6	2.9
$\Phi P$	3.0	3.5





典型性能 Typical Performance

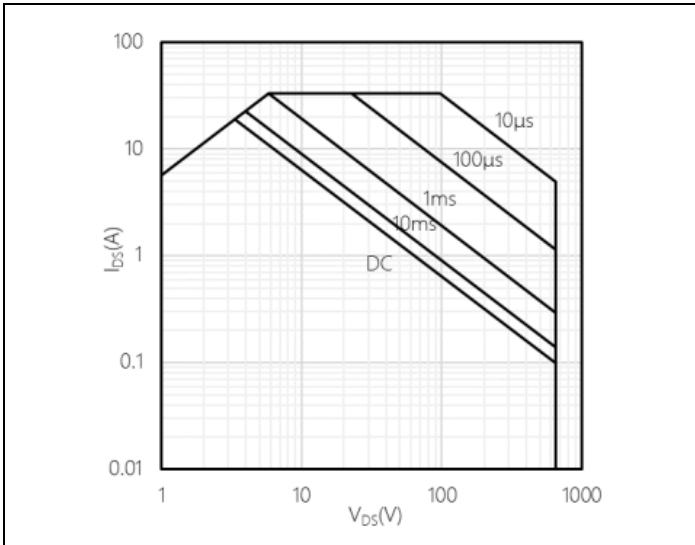

Safe operating area (SOA)

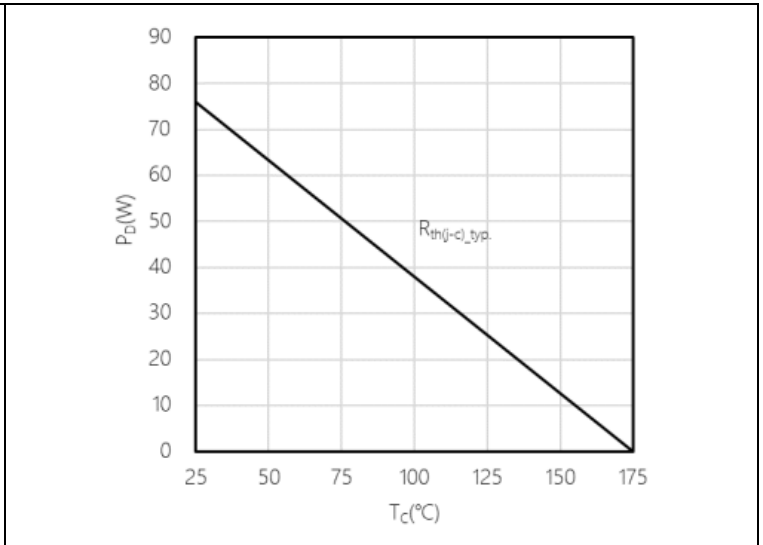

Power Derating

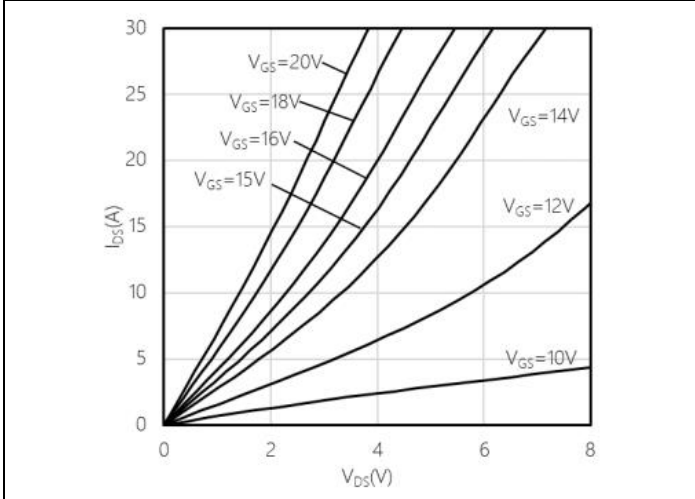

Typical output characteristic,  $V_{GS}$  as parameter  
 $T_{VJ} = -55^{\circ}\text{C}$

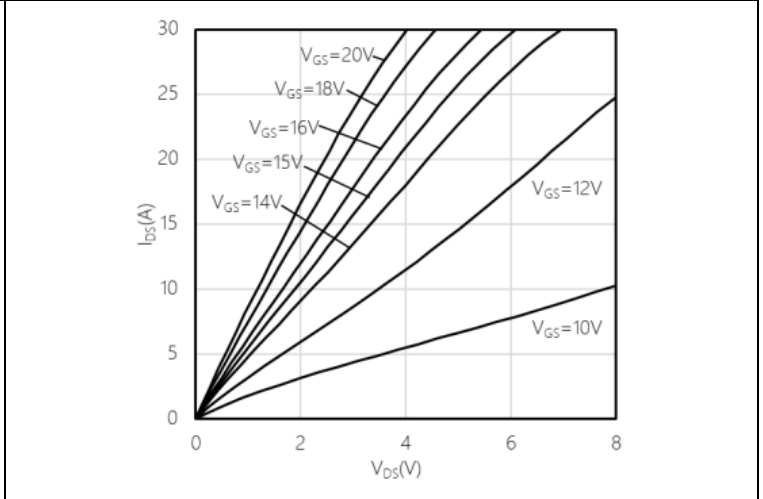

Typical output characteristic,  $V_{GS}$  as parameter  
 $T_{VJ} = 25^{\circ}\text{C}$

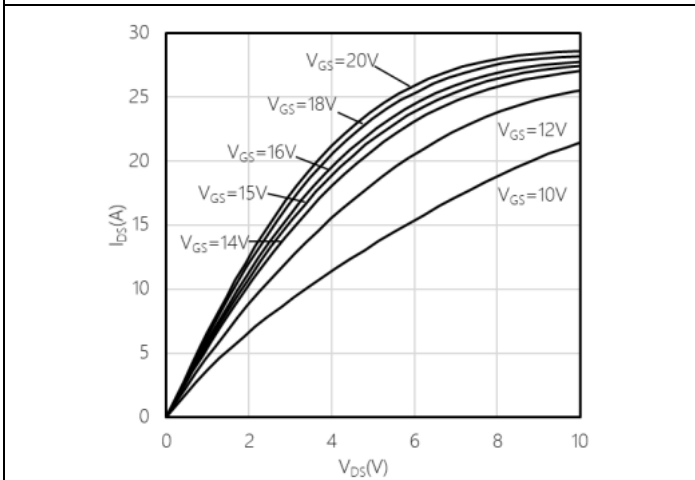

Typical output characteristic,  $V_{GS}$  as parameter  
 $T_{VJ} = 175^{\circ}\text{C}$

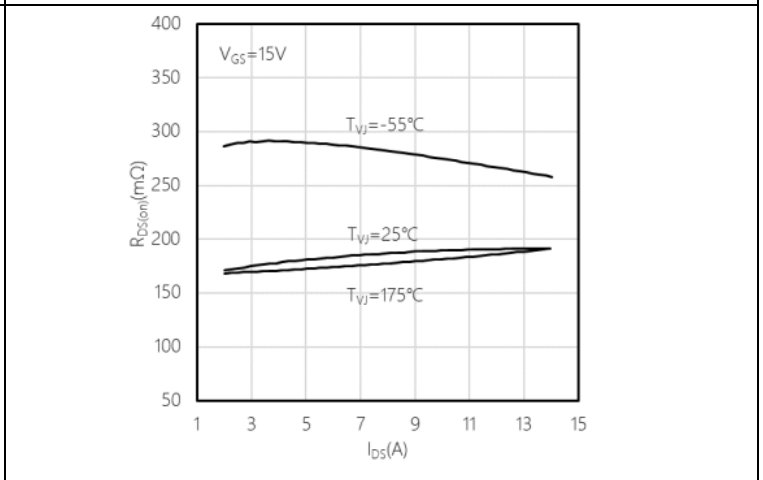

Typical on-state resistance as a function of drain current

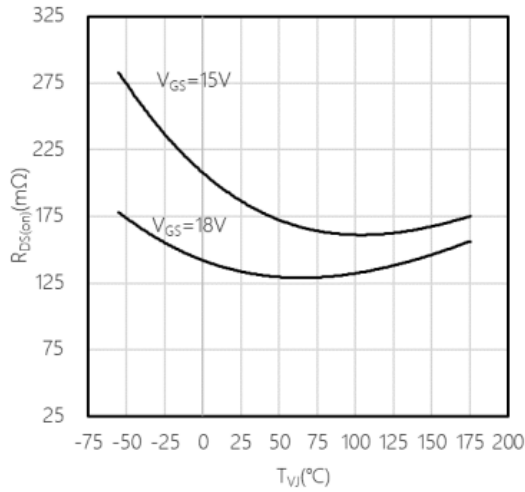

Typical on-state resistance as a function of temperature

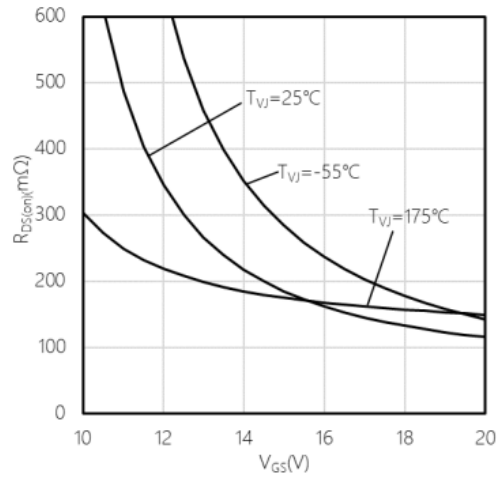

Typical on-state resistance as a function of V<sub>GS</sub>

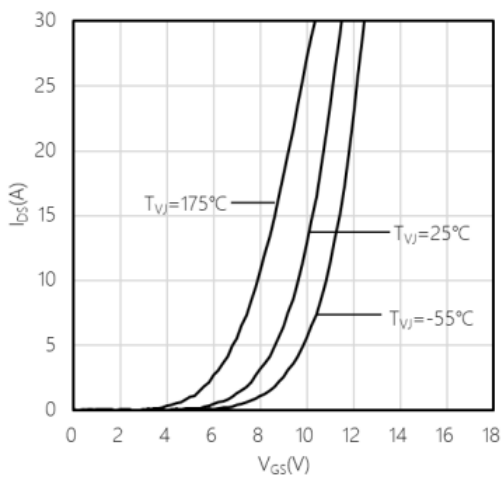

Typical transfer characteristic

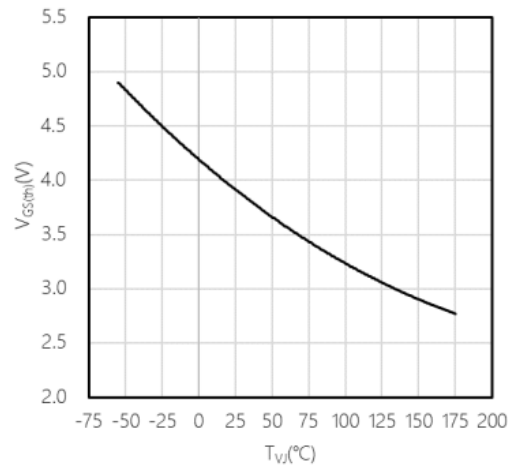

Typical gate-source threshold voltage as a function of junction temperature

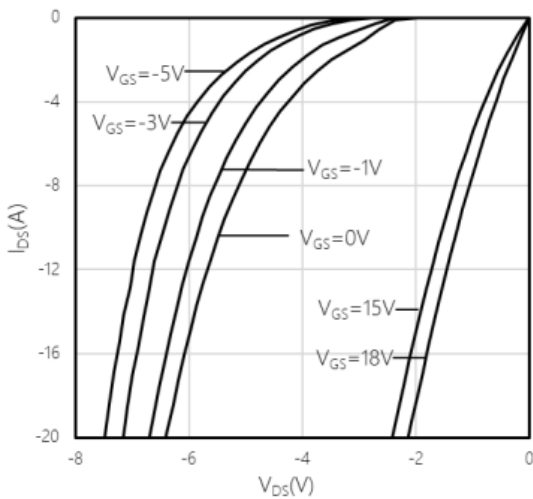

Typical reverse drain current as function of reverse drain voltage, V<sub>GS</sub> as parameter  $I_{DS} = f(V_{DS}), T_{VJ} = -55\text{ }^{\circ}\text{C}$

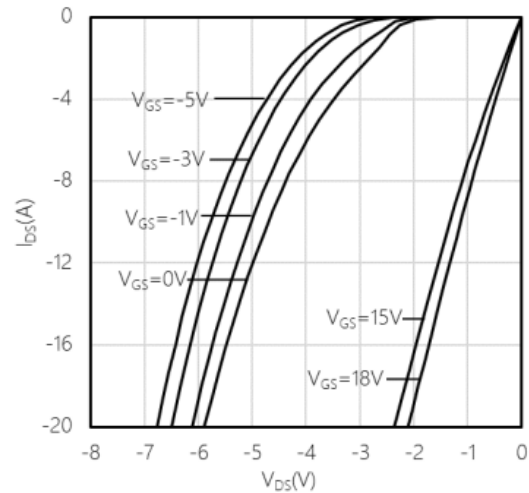

Typical reverse drain current as function of reverse drain voltage, V<sub>GS</sub> as parameter  $I_{DS} = f(V_{DS}), T_{VJ} = 25\text{ }^{\circ}\text{C}$

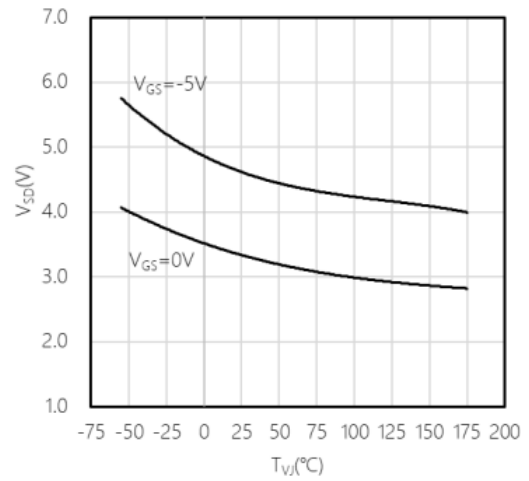
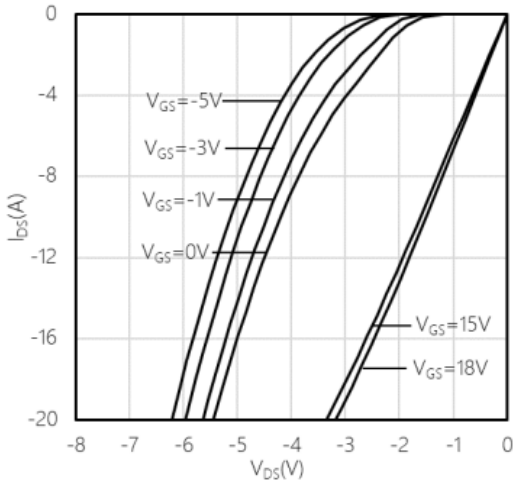

Typical reverse drain current as function of reverse drain voltage, VGS as parameter  $I_{DS} = f(V_{DS}), T_{VJ} = 175\text{ °C}$

Typical reverse drain voltage as function of junction temperature  $V_{SD} = f(T_{VJ}), I_{SD} = 2\text{ A}$

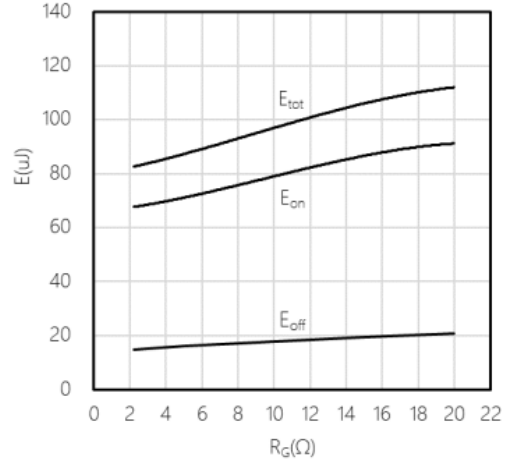
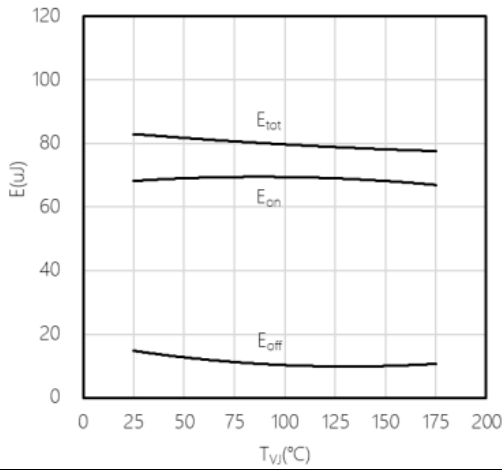

Typical switching energy as a function of junction temperature, 2nd device own body diode

Typical switching energy losses as a function of gate resistance, 2nd device own body diode  $T_{VJ} = 25\text{ °C}$

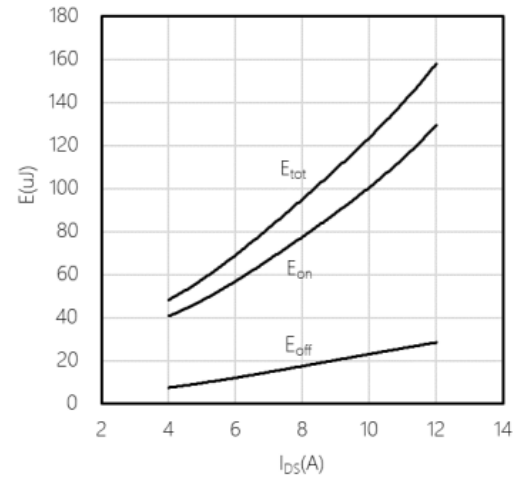
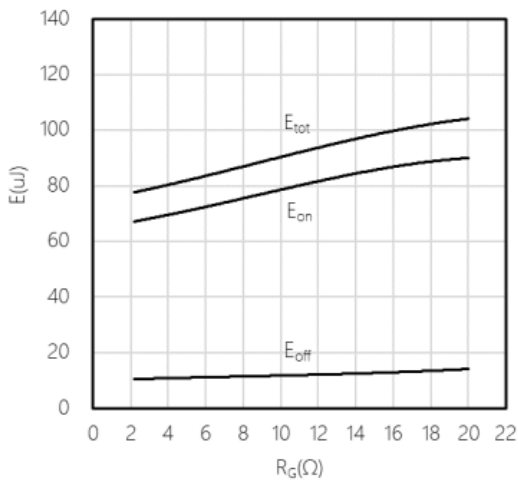

Typical switching energy losses as a function of gate resistance, 2nd device own body diode  $T_{VJ} = 175\text{ °C}$

Typical switching energy losses as a function of  $I_{DS}$ , 2nd device own body diode  $T_{VJ} = 25\text{ °C}$

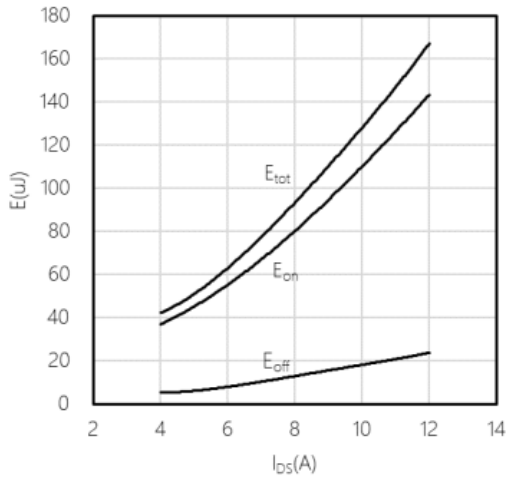

Typical switching energy losses as a function of  $I_{DS}$ , 2nd device own body diode  $T_{VJ} = 175\text{ °C}$

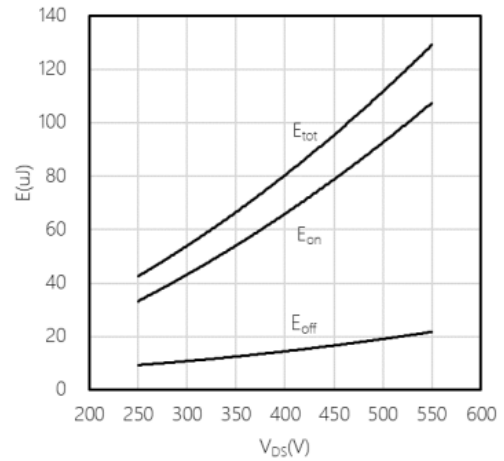

Typical switching energy losses as a function of  $V_{DS}$ , 2nd device own body diode  $T_{VJ} = 25\text{ °C}$

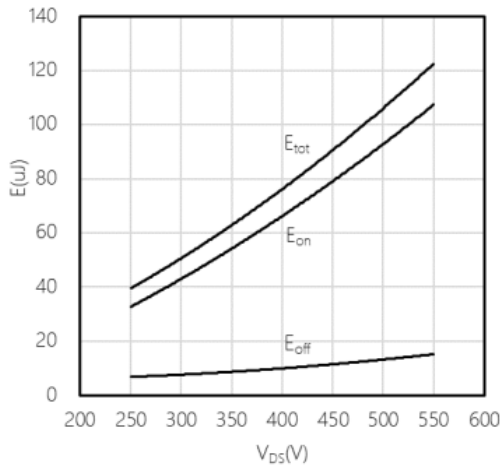

Typical switching energy losses as a function of  $V_{DS}$ , 2nd device own body diode  $T_{VJ} = 25\text{ °C}$

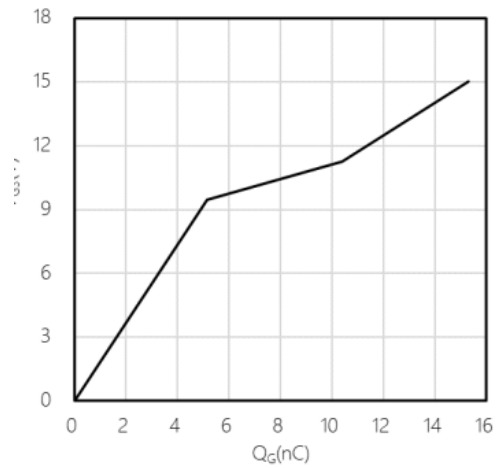

Typical gate charge

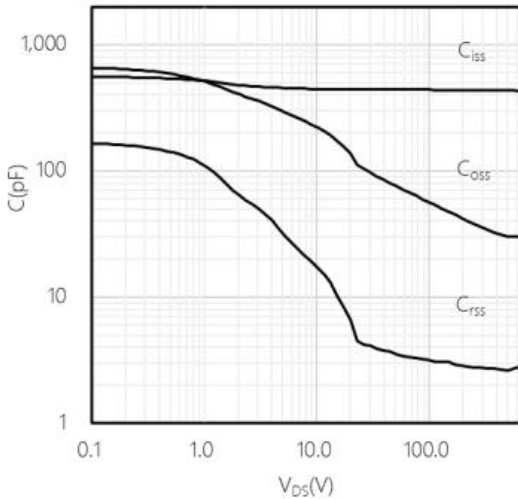

Typical capacitance as a function of drain-source voltage

$(Z_{th(j-c,max)} = f(t_p), \text{Parameter } D = t_p/T$

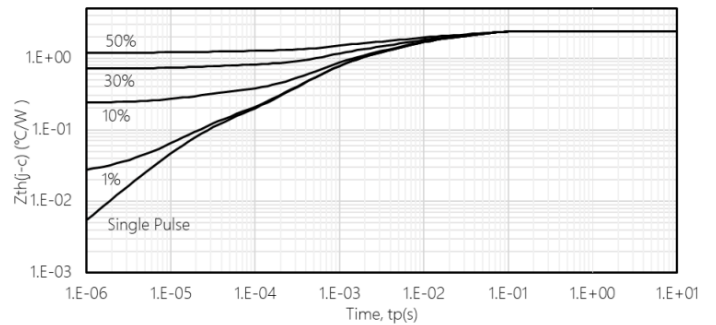

Transient thermal resistance (MOSFET)



## 外形尺寸 PACKAGE MECHANICAL DATA

## DPAK

单位 Unit: mm

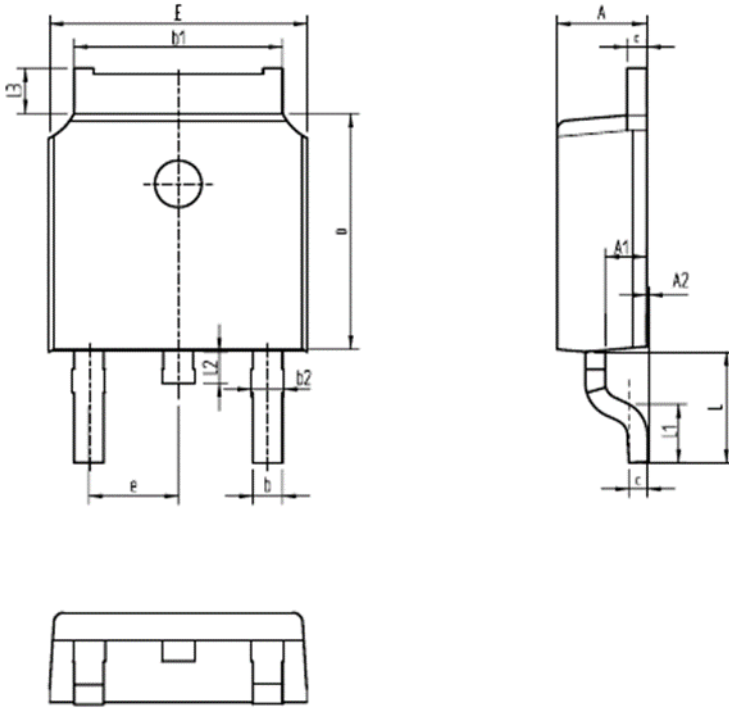

SYMBOL	mm	
	MIN	MAX
A	2.16	2.41
A1	0.97	1.17
A2	0.00	0.15
b	0.63	0.93
b1	5.13	5.53
b2	0.66	0.96
c	0.40	0.60
D	5.80	6.40
E	6.30	6.90
e	2.286BSC	
L	2.50	3.30
L1	1.20	1.80
L2	0.60	1.00
L3	0.85	1.30





### 注意事项

1. 吉林华微电子股份有限公司的产品销售分为直销和销售代理，无论哪种方式，订货时请与公司核实。
2. 购买时请认清公司商标，如有疑问请与公司本部联系。
3. 在电路设计时请不要超过器件的绝对最大额定值，否则会影响整机的可靠性。
4. 本说明书如有版本变更不另外告知。

### NOTE

1. Jilin Sino-microelectronics co., Ltd sales its product either through direct sales or sales agent , thus, for customers, when ordering , please check with our company.
2. We strongly recommend customers check carefully on the trademark when buying our product, if there is any question, please don't be hesitate to contact us.
3. Please do not exceed the absolute maximum ratings of the device when circuit designing.
4. Jilin Sino-microelectronics co., Ltd reserves the right to make changes in this. specification sheet and is subject to change without prior notice.

### 联系方式

#### 吉林华微电子股份有限公司

公司地址：吉林省吉林市深圳街 99 号

邮编：132013

总机：86-432-64678411

传真：86-432-64665812

网址：[www.hwdz.com.cn](http://www.hwdz.com.cn)

### CONTACT

#### JILIN SINO-MICROELECTRONICS CO., LTD.

ADD: No.99 Shenzhen Street, Jilin City, Jilin Province, China.

Post Code: 132013

Tel: 86-432-64678411

Fax: 86-432-64665812

Web Site: [www.hwdz.com.cn](http://www.hwdz.com.cn)

