



# JT050N065F7PB1E

## 主要参数 MAIN CHARACTERISTICS

$I_C$	50A
$V_{CES}$	650V
$V_{cesat\_typ}$ ( $V_{ge}=15V$ )	1.5V

### 用途

- 辅助逆变器
- 电机传动
- 空调

### 产品特性

- FS 技术
- 低通态压降,  $V_{CE(sat)}$ ,  
typ = 1.5V,  $I_C = 50A$  and  
 $T_C = 25^\circ C$
- $V_{CEsat}$  正温度系数
- 低开关损耗

### APPLICATIONS

- Auxiliary inverter
- Motor Drives
- air conditioning

### FEATURES

- FS Technology
- Low saturation voltage:  
 $V_{CE(sat)}$ , typ = 1.5V,  $I_C =$   
50A and  $T_C = 25^\circ C$
- $V_{CEsat}$  with positive  
Temperature Coefficient
- Low Switching Losses

## 封装 Package

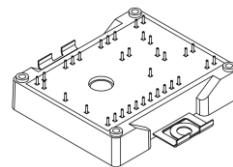

外形示意图

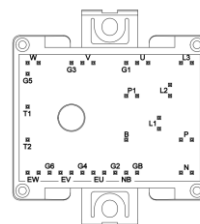

引脚示意图

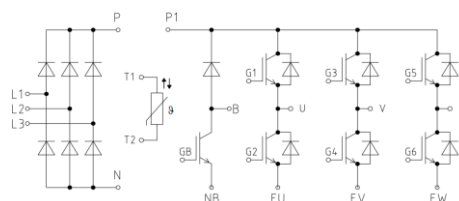

电路示意图

## 订货信息 ORDER MESSAGE

订货型号 Order codes	印记 Marking	封装 Package	包装 Packaging	器件重量 Device Weight
JT050N065F7PB1E	JT050N065F7PB1E	EasyPim2B 模块	盒装	39g(typ)



绝对最大额定值 ABSOLUTE RATINGS ( $T_c=25^\circ\text{C}$ )

## IGBT, 逆变器/制动、斩波 IGBT, Inverter/Brake-Chopper

项 目 Parameter	条件	符 号 Symbol	数 值 Value	单 位 Unit
最高集电极-发射极直流电压 Collector-Emmitter Voltage	$T_{vj}=25^\circ\text{C}$	$V_{ces}$	650	V
连续集电极极电流 Collector Current-continuous	$T_c=75^\circ\text{C}, T_{vj}=175^\circ\text{C};$ $T_c=25^\circ\text{C}, T_{vj}=175^\circ\text{C}$	$I_c$	50 65	A A
最大脉冲集电极极电流 (注 1) Collector Current – pulse (note 1)	$t_p = 1 \text{ ms}$	$I_{CM}$	100	A
最高栅极发射极电压 Gate-Emmitter Voltage		$V_{GES}$	$\pm 20$	V
短路时间 short circuit time		$t_{sc}$	10	$\mu\text{s}$
耗散功率 Power Dissipation	$T_c=25^\circ\text{C}, T_{vj}=175^\circ\text{C}$	$P_D$	166	W
结温范围 Junction Temperature		$T_{vjmax}$	175	°C
		$T_{vjop}$	-40~+150	

## 二极管, 逆变器/制动、斩波/FRD, Inverter/Brake-Chopper

项 目 Parameter	条件	符 号 Symbol	数 值 Value	单 位 Unit
反向重复峰值电压 Repetitive peak reverse voltage	$T_{vj} = 25^\circ\text{C}$	$V_{RRM}$	650	V
连续正向直流电流 Continuous DC forward current		$I_F$	50	A
正向重复峰值电流 Repetitive peak forward current	$t_p = 1 \text{ ms}$	$I_{FRM}$	100	A
$I^2t$ -值 $I^2t$ value	$V_R = 0 \text{ V}, t_p = 10 \text{ ms}, T_{vj} = 150^\circ\text{C}$	$I^2t$	330	$\text{A}^2\text{S}$





## 二极管, 整流器/Diode, Rectifier

项 目 Parameter	条 件	符 号 Symbol	数 值 Value	单 位 Unit
反向重复峰值电压 Repetitive peak reverse voltage	$T_{vj} = 25^{\circ}\text{C}$	$V_{RRM}$	1600	V
最大正向均方根电流(每芯片) Maximum RMS forward current per chip	$T_c = 100^{\circ}\text{C}$	$I_{FRMSM}$	60	A
最大整流器输出均方根电流 Maximum RMS current at rectifier output	$T_c = 100^{\circ}\text{C}$	$I_{RMSM}$	60	A
正向浪涌电流 Surge forward current	$t_p = 10 \text{ ms}, T_{vj} = 25^{\circ}\text{C}$ $t_p = 10 \text{ ms}, T_{vj} = 150^{\circ}\text{C}$	$I_{FSM}$	450 370	A
$I^2t$ -值 $I^2t$ value	$V_R = 0 \text{ V}, t_p = 10 \text{ ms}, T_{vj} = 25^{\circ}\text{C}$	$I^2t$	1000	$\text{A}^2\text{S}$ $\text{A}^2\text{S}$





## 电特性 ELECTRICAL CHARACTERISTICS

## IGBT, 逆变器/制动、斩波 IGBT, Inverter/Brake-Chopper

项 目 Parameter	符 号 Symbol	测试条件 Tests conditions	最小 Min	典型 Typ	最大 Max	单位 Unit
<b>关态特性 Off –Characteristics</b>						
集电极—发射极击穿电压 Collector-Emmitter Voltage	$BV_{CES}$	$I_C=1mA, V_{GE}=0V$	650	-	-	V
零栅压下集电极漏电流 Zero Gate Voltage Collector Current	$I_{CES}$	$V_{CE}=650V, V_{GE}=0V, T_C=25^\circ C$	-	-	1	mA
正向栅极体漏电流 Gate-body leakage current, forward	$I_{GESF}$	$V_{CE}=0V, V_{GE}=20V$	-	-	200	nA
反向栅极体漏电流 Gate-body leakage current, reverse	$I_{GESR}$	$V_{CE}=0V, V_{GE}=-20V$	-	-	-200	nA
<b>通态特性 On-Characteristics</b>						
阈值电压 Gate-Emmitter Threshold Voltage	$V_{GE(th)}$	$V_{CE} = V_{GE}, I_C=0.25mA$	5.2	5.85	6.5	V
饱和压降 Collector-Emmitter saturation Voltage	$V_{CESAT}$	$V_{GE}=15V, I_C=50A$ $T_C=25^\circ C$ $T_C=150^\circ C$	- - -	1.5 1.75	2.1 -	V
短路电流（注2） Short Collector current (Note 2)	$I_C(SC)$	$V_{GE}=15V, V_{CE}=300V, t_{SC} < 10\mu s$ $T_C=25^\circ C$		260		A
<b>动态特性 Dynamic Characteristics</b>						
输入电容 Input capacitance	$C_{ies}$	$V_{CE}=25V, V_{GE}=0V,$ $f=1.0MHz$	-	3.43		nF
输出电容 Output capacitance	$C_{oes}$		-	0.28		nF
反向传输电容 Reverse transfer capacitance	$C_{res}$		-	0.079		nF

注释:

- 1: 脉冲宽度由最高结温限制
- 2: 两次短路之间的间隔大于 1 秒时, 允许短路测试的次数最大为 1000 次

Notes:

- 1: Pulse width limited by maximum junction temperature
- 2: Allowed number of short circuits: <1000; time between short circuits: >1s.





## 电特性 ELECTRICAL CHARACTERISTICS

## IGBT, 逆变器/制动、斩波 IGBT, Inverter/Brake-Chopper

项 目 Parameter	符 号 Symbol	测试条件 Tests conditions	最小 Min	典型 Typ	最大 Max	单位 Unit
开关特性 Switching Characteristics						
开启延迟时间 Turn-On delay time	$t_d(\text{on})$	$V_{CC}=300V, I_c=50A, R_G=10\Omega, V_{GE}=15V$ , 感性负载 (500uH)	$T_C=25^\circ\text{C}$	15	-	ns
上升时间 Turn-On rise time	$t_r$		$T_C=25^\circ\text{C}$	30	-	ns
关断延迟时间 Turn-Off delay time	$t_d(\text{off})$		$T_C=25^\circ\text{C}$	48	-	ns
下降时间 Turn-Off Fall time	$t_f$		$T_C=25^\circ\text{C}$	75	-	ns
开通损耗 Turn-On energy	$E_{\text{on}}$		$T_C=25^\circ\text{C}$	0.8	-	mJ
关断损耗 Turn-off energy	$E_{\text{off}}$		$T_C=25^\circ\text{C}$	0.62	-	mJ
总开关损耗 Total switching energy	$E_{\text{tot}}$		$T_C=25^\circ\text{C}$	1.42	-	mJ
开启延迟时间 Turn-On delay time	$t_d(\text{on})$	$V_{CC}=300V, I_c=50A, R_G=10\Omega, V_{GE}=15V$ , 感性负载 (500uH)	$T_C=150^\circ\text{C}$	14	-	ns
上升时间 Turn-On rise time	$t_r$		$T_C=150^\circ\text{C}$	30	-	ns
关断延迟时间 Turn-Off delay time	$t_d(\text{off})$		$T_C=150^\circ\text{C}$	50	-	ns
下降时间 Turn-Off Fall time	$t_f$		$T_C=150^\circ\text{C}$	80	-	ns
开通损耗 Turn-On energy	$E_{\text{on}}$		$T_C=150^\circ\text{C}$	1.0	-	mJ
关断损耗 Turn-off energy	$E_{\text{off}}$		$T_C=150^\circ\text{C}$	0.8	-	mJ
总开关损耗 Total switching energy	$E_{\text{tot}}$		$T_C=150^\circ\text{C}$	1.8	-	mJ
栅极电荷总量 Total Gate Charge	$Q_g$	$V_{GE}=-15V \dots +15V$	-	121	-	nC
内部栅极电阻 Internal gate resistance	$R_{Gint}$	$f=1\text{ MHz, open collector}$		2		$\Omega$
结-外壳热阻 Thermal resistance junction to case	$R_{thJC}$	每个IGBT per IGBT		0.8	0.9	K/W





外壳—散热器热阻 Thermal resistance case to heatsink	$R_{thCH}$	每个IGBT per IGBT $\lambda_{Paste} = 1 \text{ W}/(\text{m}\cdot\text{K}) /$ $\lambda_{grease} = 1 \text{ W}/(\text{m}\cdot\text{K})$		0.7		K/W
开关下的温度 Temperature under switching conditions	$T_{vjop}$		-40		150	$^{\circ}\text{C}$

**二极管, 逆变器/制动、斩波/FRD, Inverter/Brake-Chopper**

项 目 Parameter	符 号 Symbol	测试条件 Tests conditions	最小 Min	典型 Typ	最大 Max	单位 Unit
<b>二极管特性 Diode Characteristics</b>						
正向压降 Drain-Source Diode Forward Voltage	$V_F$	$V_{GE}=0\text{V}, I_F=50\text{A},$ $TC=25^{\circ}\text{C}$	-	1.85	2.3	V
		$V_{GE}=0\text{V}, I_F=50\text{A},$ $TC=150^{\circ}\text{C}$	-	1.6	-	V
反向恢复时间 Diode Reverse recovery time	$t_{rr}$	$I_F = 50 \text{ A}, - diF/dt =$ $2200 \text{ A}/\mu\text{s} (T_{vj}=25^{\circ}\text{C})$ $VR = 300 \text{ V}$ $V_{GE} = -15 \text{ V}$	-	48	-	ns
反向恢复电荷 Diode Reverse recovery charge	$Q_{rr}$		-	1140	-	nC
反向恢复电流 Diode Reverse recovery Current	$I_{RRM}$		-	43	-	A
反向恢复损耗（每脉冲） Reverse recovery energy	Erec				0.45	
反向恢复时间 Diode Reverse recovery time	$t_{rr}$	$I_F = 50 \text{ A}, - diF/dt =$ $2200 \text{ A}/\mu\text{s} (T_{vj}=150^{\circ}\text{C})$ $VR = 300 \text{ V}$ $V_{GE} = -15 \text{ V}$	-	56	-	ns
反向恢复电荷 Diode Reverse recovery charge	$Q_{rr}$		-	1380	-	nC
反向恢复电流 Diode Reverse recovery Current	$I_{RRM}$		-	48	-	A
反向恢复损耗（每脉冲） Reverse recovery energy	Erec				0.54	
结—外壳热阻 Thermal resistance junction to case	$R_{thJC}$	每个二极管 per diode		1.1	1.2	K/W
外壳—散热器热阻 Thermal resistance case to heatsink	$R_{thCH}$	每个二极管 per diode $\lambda_{Paste} = 1 \text{ W}/(\text{m}\cdot\text{K}) /$ $\lambda_{grease} = 1 \text{ W}/(\text{m}\cdot\text{K})$		0.9		K/W
开关下的温度 Temperature under switching conditions	$T_{vjop}$		-40		150	$^{\circ}\text{C}$



## 电特性 ELECTRICAL CHARACTERISTICS

## 二极管，整流器/Diode, Rectifier

项 目 Parameter	符 号 Symbol	测试条件 Tests conditions	最小 Min	典型 Typ	最大 Max	单位 Unit
二极管特性 Diode Characteristics						
正向压降（芯片） Diode Forward Voltage	$V_F$	$V_{GE}=0V, I_F=50A$	-	1.15	-	V
反向电流 Reverse current	$I_R$	$T_{vj} = 150^{\circ}C,$ $V_R = 1600 V$		1		mA
结—外壳热阻 Thermal resistance junction to case	$R_{thJC}$	每个二极管 per diode		1.05	1.15	K/W
外壳—散热器热阻 Thermal resistance case to heatsink	$R_{thCH}$	每个二极管 per diode $\lambda_{Paste} = 1 W/(m \cdot K) /$ $\lambda_{grease} = 1 W/(m \cdot K)$		0.95		K/W

## 负温度系数热敏电阻/NTC-Thermistor

项 目 Parameter	符 号 Symbol	最小 Min	典型 Typ	最大 Max	单位 Unit	
额定电阻值 Rated resistance	$R_{25^{\circ}C}$	4.75	5	5.25	kohm	
时间常数 静止空气中	$\tau$	-	-	10	Sec	
最大额定功率	$P_{max}$	-	-	10	mW	
B-值 B-value	$B = [(T_a \times T_b) / (T_b - T_a)] \times \ln(R_a / R_b)$ $T_b = 50^{\circ}C \pm 0.01^{\circ}C$	$B_{25/50}$	3346.2	3380	3413.8	K
工作温度	-	-50	-	200	$^{\circ}C$	



## 模块特性/Module Characteristics

项 目 Parameter	符 号 Symbol	测试条件 Tests conditions	最小 Min	典型 Typ	最大 Max	单位 Unit
绝缘测试电压 Isolation test voltage	V <sub>ISOL</sub>	RMS, f = 50 Hz, t = 1min		2.5		KV
内部绝缘 Internal isolation	基本绝缘 (class 1, IEC 61140) Basic insulation (class1, IEC 61140)		Al2O3			
爬电距离 Creepage distance		端子-散热片 terminal to heatsink	-	11.5	-	mm
		端子-端子 Terminal to terminal	-	6.3	-	
电气间隙 Clearance		端子-散热片 terminal to heatsink	-	10	-	mm
		端子-端子 Terminal to terminal	-	5	-	
相对电痕指数 Comperative tracking index	CT1		200			
杂散电感,模块 Stray inductance module	L <sub>SCE</sub>			30		nH
模块引线电阻,端子-芯片 Module lead resistance terminals chip	R <sub>CC'+EE'</sub> R <sub>AA'+CC'</sub>			6		mΩ
储存温度 Storage temperature	T <sub>stg</sub>		-40		125	°C
安装力 Anpresskraft fur mech. Bef. pro Feder mountig force per clamp	F		40		80	N
重量 Weight	G		-	39	-	g

## 注释(Notes):

连续运行的电流有效地限制在每个连接引脚 30A。

Der Strom im Dauerbetrieb ist auf 30A effektiv pro Anschlusspin begrenzt.

连续工作时，每个连接器引脚的电流限制为 30A rms。

The current under continuous operation is limited to 30A rms per connector pin.







特征曲线 ELECTRICAL CHARACTERISTICS (curves)

**IGBT Typical Output Characteristics(Tvj=25°C)**

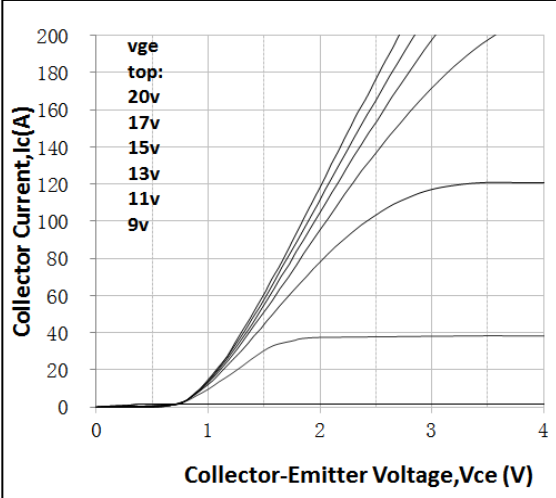

**IGBT Typical Output Characteristics(Tvj=150°C)**

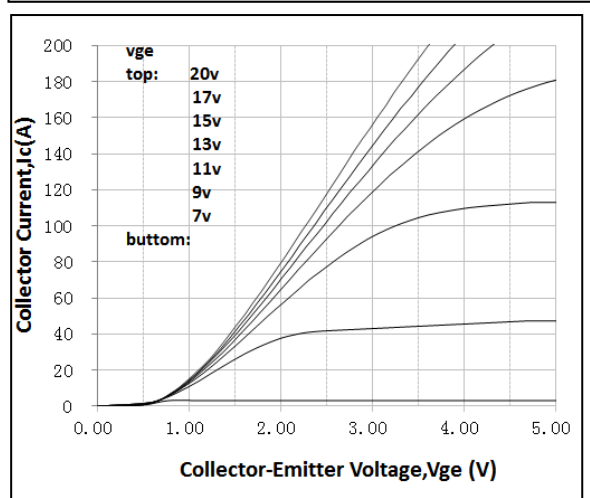

**IGBT Transfer characteristic**

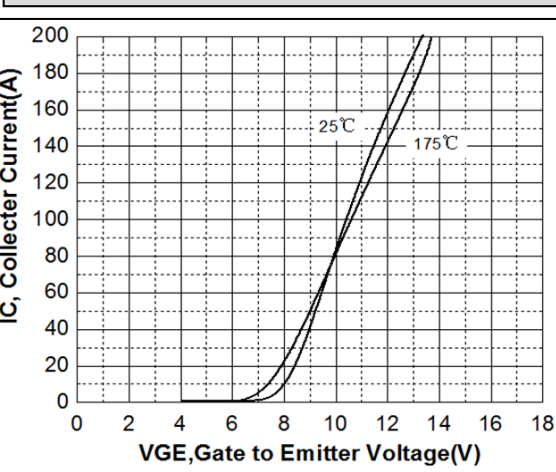

**IGBT Vcesat vs. Tj**

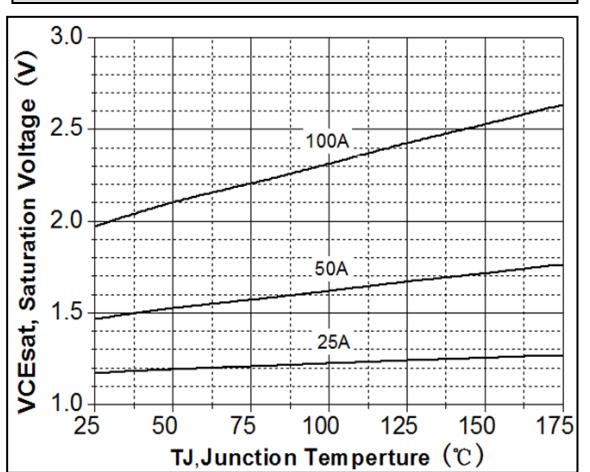

**IGBT Switching Loss vs. Rg(25°C)**  
VGE=15V, VCE=300V, IC=50A

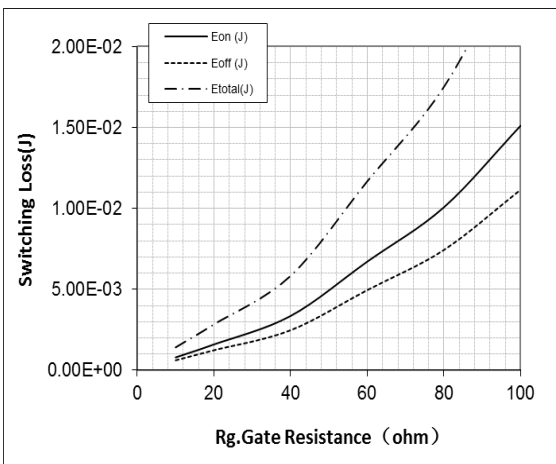

**IGBT Switching Loss vs. IC(25°C)**  
VGE=15V, VCE=300V, Rg=10Ω

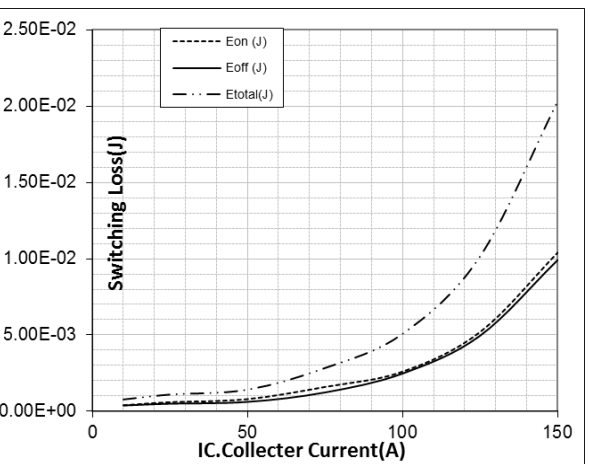



### IGBT Switching Loss vs. IC(150°C) VGE=15V,VCE=300V,Rg=10Ω

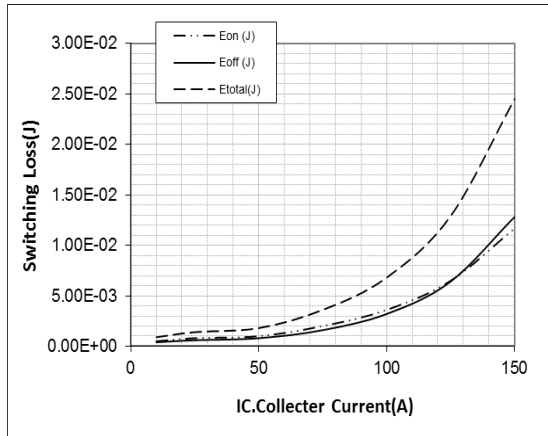

### RBSOA of IGBT

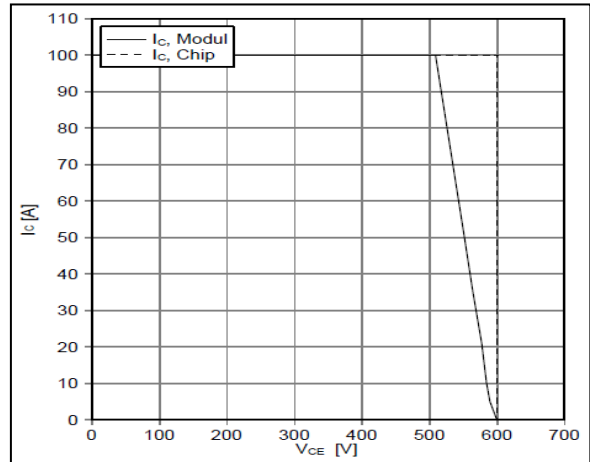

### Transient Thermal Impedance (IGBT)

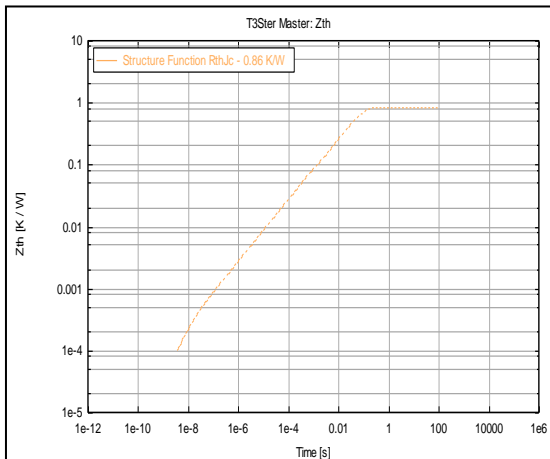

### Inverter FRD Forward Characteristics

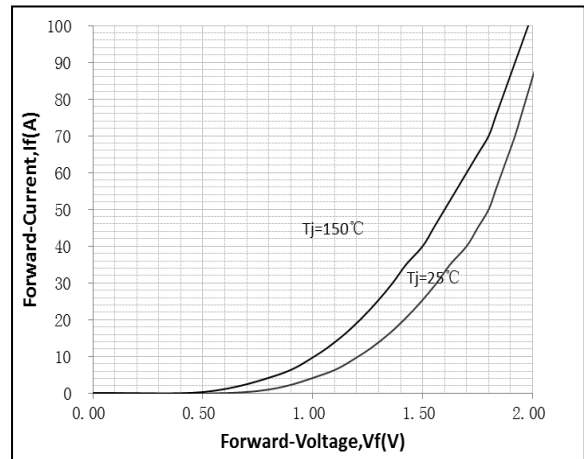

### Transient Thermal Impedance (FRD)

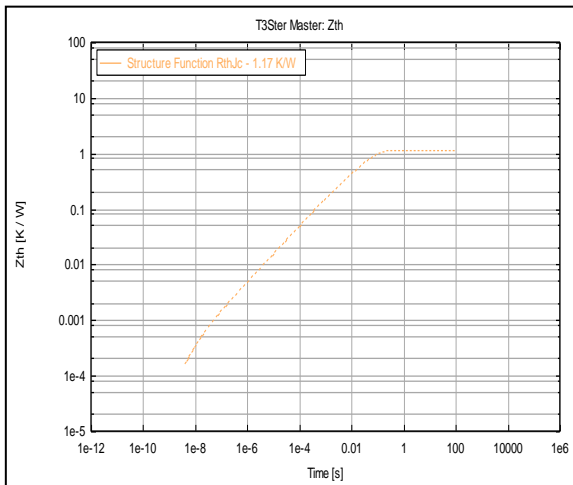

### NTC-Thermistor-temperature characteristic (typical)

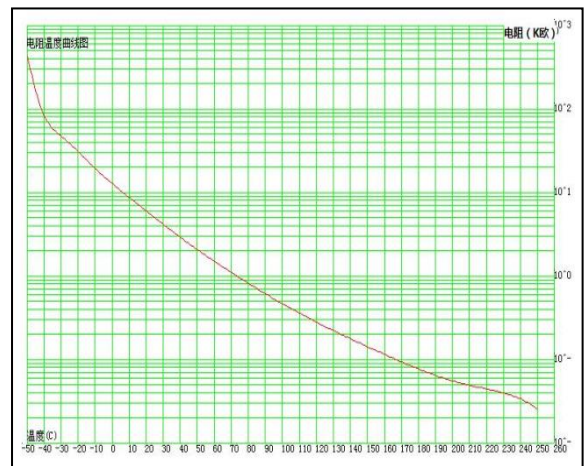



外形尺寸 PACKAGE MECHANICAL DATA  
Circuit diagram

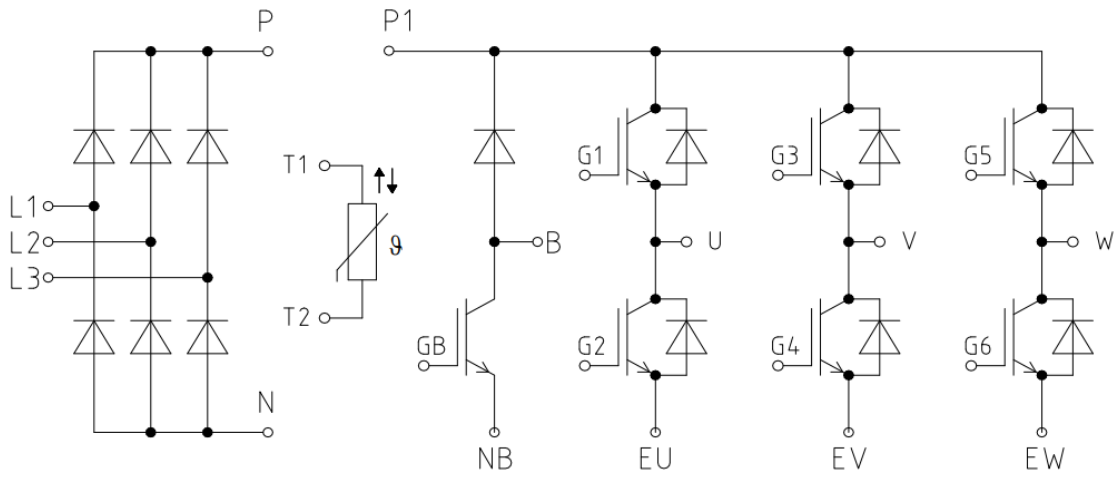



Package outlines

单位 Unit: mm

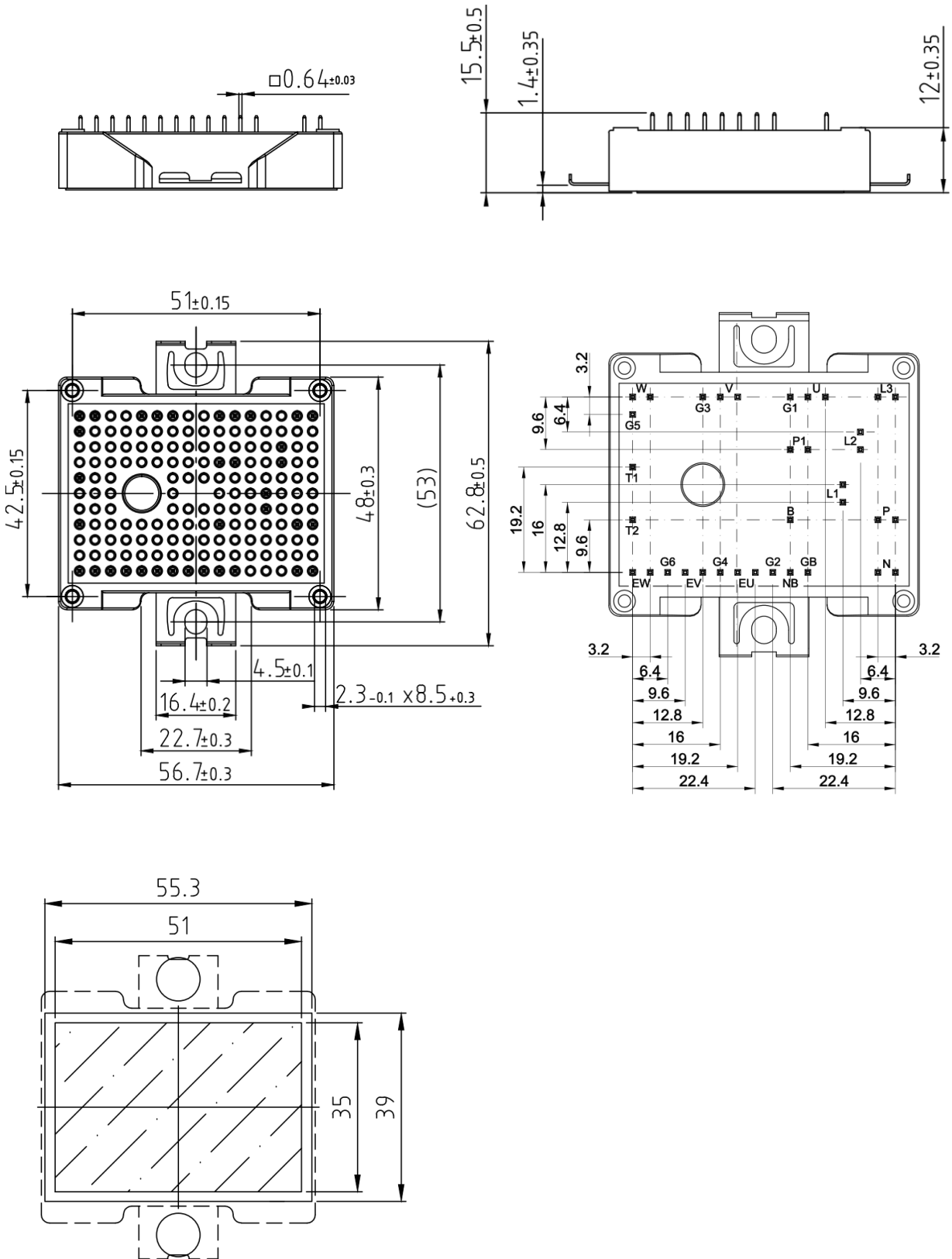

Restricted area for thermal interface material



### 注意事项

1. 吉林华微电子股份有限公司的产品销售分为直销和销售代理，无论哪种方式，订货时请与公司核实。
2. 购买时请认清公司商标，如有疑问请与公司本部联系。
3. 在电路设计时请不要超过器件的绝对最大额定值，否则会影响整机的可靠性。
4. 本说明书如有版本变更不另外告知。

### NOTE

1. Jilin Sino-microelectronics co., Ltd sales its product either through direct sales or sales agent , thus, for customers, when ordering , please check with our company.
2. We strongly recommend customers check carefully on the trademark when buying our product, if there is any question, please don't be hesitate to contact us.
3. Please do not exceed the absolute maximum ratings of the device when circuit designing.
4. Jilin Sino-microelectronics co., Ltd reserves the right to make changes in this. specification sheet and is subject to change without prior notice.

### 联系方式

#### 吉林华微电子股份有限公司

公司地址：吉林省吉林市深圳街 99 号

邮编：132013

总机：86-432-64678411

传真：86-432-64665812

网址：[www.hwdz.com.cn](http://www.hwdz.com.cn)

### CONTACT

#### JILIN SINO-MICROELECTRONICS CO., LTD.

ADD: No.99 Shenzhen Street, Jilin City, Jilin Province, China.

Post Code: 132013

Tel: 86-432-64678411

Fax: 86-432-64665812

Web Site: [www.hwdz.com.cn](http://www.hwdz.com.cn)